

NQAC, HQAC, SQAC, EQAC AIR-COOLED CONDENSERS

OPERATING AND INSTALLATION INSTRUCTIONS

SECTION A - CONDENSER LOCATION:

The primary considerations for air cooled condenser location are:

- 1 Essentially unrestricted airflow onto and away from the finned coil heat exchange surface.
- 2 **Prevention of discharge air being re-circulated** back to the air inlet side of the condenser.

The capacity of the condenser relates directly to the quantity and dry bulb temperature of the air entering the heat exchange surface. The wet bulb temperature and effect of the sun's rays has no significant bearing on the capacity of an air-cooled condenser.

Ideally condensers should be located a minimum distance of one fan diameter from any adjacent walls or other units though this is not critical if other arrangements are made to ensure normal airflow is not restricted or **that re-circulation does not occur**. Particular care should be taken in this respect when installing larger capacity units in walled areas between multi-story buildings. Care should also be taken to ensure that the supply air temperature is the same as the ambient air temperature. If air is taken from an area where there is a build-up of heat (such as over restricted roof areas), then the capacity of the unit will be reduced resulting in higher operating condensing pressures.

When horizontal airflow condensers are mounted on rooftops, the air inlet side should face away from the rooftop to minimize high temperature air close to the roof surfaces being dragged into the condenser inlet. If necessary, vertical airflow condensers should be elevated above rooftop surfaces, and extended legs are available as an option at extra cost.

It is important to carefully consider the effect that any wind may have on airflow. Horizontal discharge models should be sited so that the air inlet coil side faces prevailing winds. If strong winds may be encountered blowing into the air discharge side, then provision should be made to install a wind deflector on this side of the condenser. Vertical discharge models are normally not affected by winds.

Smaller capacity condensers may be installed in basement areas, however, again it is important to ensure relatively free dissipation of the discharge air. Any unit installed indoors must have provision for ducting the entire quantity of discharge air to the outdoors.

Where it is necessary to install discharge ducts as a guide, the cross sectional area of the duct should be 100% greater than the cross sectional area of the fan outlets and maximum length of duct should be restricted to 10 equivalent metres. Guards cannot be removed, as the guard also supports the motor. A flexible duct connection will minimize noise transmission. If louvres are installed on the duct outlet the free open area should not be less than the duct cross sectional area

SECTION B - INSTALLATION:

Smaller models NQAC150 to NQAC650 can normally be handled by hand, NQAC750 through to NQAC3000, are normally moved onto their site location using forklifts or hydraulic hoists, from planking (supplied by the contractor) that spans under the length of the finned coil section. A minimum of two timber planks of size 100 x 50mm should be used to span the length between the coil end plates as shown below;

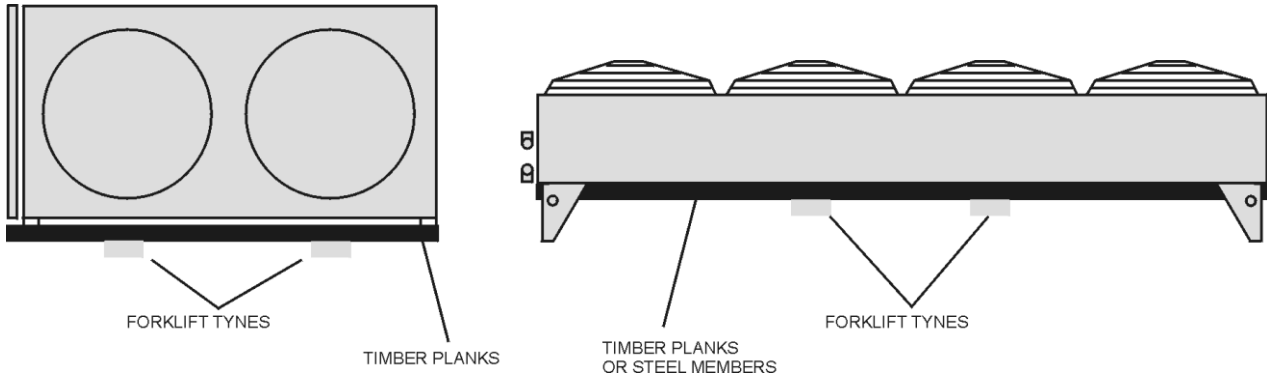

Where site cranes are used, special lifting brackets (part No. BAC-LS) are available for models (N,H,S,E)QAC3500 through (N,H,S,E)QAC15002 at no extra cost for bolting to condenser end panels as follows (request these at time of ordering):

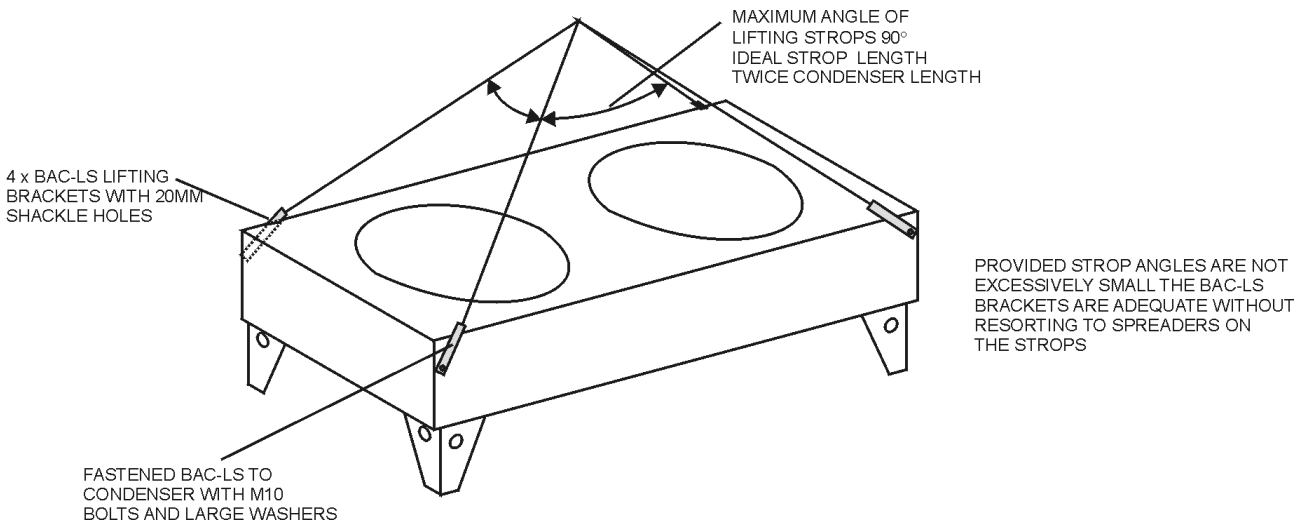

Note: Under no circumstances should coil headers or return bends be used in the handling or installation of (N,H,S,E)QAC condensers.

All condensers with **horizontal airflow configuration** need to be installed on a level plane to ensure proper, gravity drainage of condensed refrigerant and oil.

In general terms this also applies to condensers with vertical airflow configuration. The only instance in which a non-level mounting plane should be considered is when installing models NQAC150 through NQAC400 with vertical airflow configuration. In such instances, a 1 in 50 fall is recommended towards the liquid outlet connection. (see diagram page 6)

Mounting hole sizes in feet or legs are as follows:

NQAC 150 to NQAC650	10mm
NQAC750 to NQAC6002	12mm
(N,H,S,E)QAC 3500 to 15002	12mm

SECTION C - SITE ASSEMBLY OF MODELS (N,H,S,E)QAC 3500 - (N,H,S,E)QAC 15002

Due to road transport restrictions and freight considerations the above models are shipped in single or double module sections with legs packed separately. The diagram below shows the correct positioning of parts for site assembly.

Legs are fastened to condenser end plates and side panels with M10 SS machine screws. When appropriate. M8 SS machine screws are used to fasten end plate flanges of adjacent modules together on "double module" models.

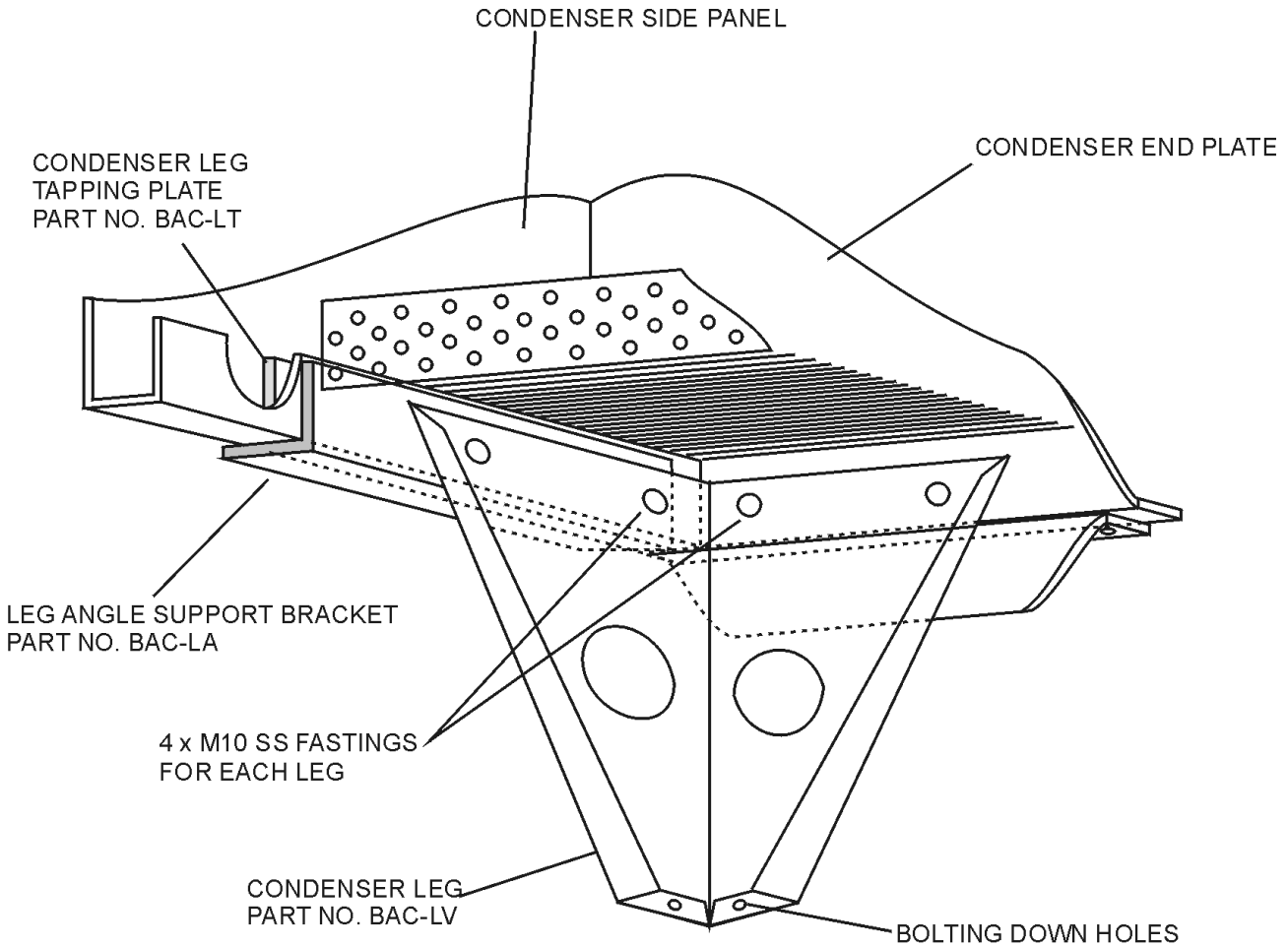

**VIEW LOOKING AT INSIDE OF LEG FROM
UNDERSIDE OF ASSEMBLED CONDENSER**

Note : Due to transportation and handling constraints:

- Three module models are supplied as one double module and one single module.
- Four module models are supplied as two double modules.
- Each single or double module has its own set of four legs.

SECTION D - FIELD PIPING

Patton condensers are supplied complete with headers and refrigerant connections sized for connecting to standard commercial refrigeration copper pipe. Inlet headers on all models are fitted with "Schrader" type purge valves. This can be used not only for purging but also for measuring discharge pressure in the absence of a discharge service valve. Patton's utilise this fitting as a quality control checkpoint for loss of pressure prior to final assembly of the condenser therefore it is also ideal for checking the integrity of a refrigerant holding charge at site before installation.

The fact that Patton air-cooled condensers are designed for zero inherent sub-cooling needs to be taken into consideration by the system designer. Should piping design not take this into consideration, it is highly likely that a loss of system performance will result.

When air-cooled condensers are used to replace water-cooled or evaporative condensers special considerations are necessary:

- VIZ.
- (1) The condenser needs to be generously sized to the best refrigeration and air conditioning practices.
 - (2) Special attention needs to be given to plant capacity and sizing of compressor motors. At high ambient, condensing temperatures will be elevated above those normally experienced with water cooled or evaporative condensers.

Good piping practices and local codes should be observed when installing remote air-cooled condensers. Current ASHRAE guidelines reflect good design practice and consequently Patton's recommend these for field piping to & from their condensers. In particular, the following should be noted:-

HOT GAS DISCHARGE LINES

Careful consideration must always be given to the sizing of hot gas pipes to ensure gas velocities remain sufficiently high to entrain and transport oil. On the other hand the velocity should not be so high as to cause excessive pressure drop

Patton's have formulated user-friendly pipe size charts for refrigeration personnel based on ASHRAE guidelines. Discharge line sizing in these charts has been based on a temperature drop of 0.02K per metre of pipe run. Please contact your nearest Patton Branch should you require a copy of these.

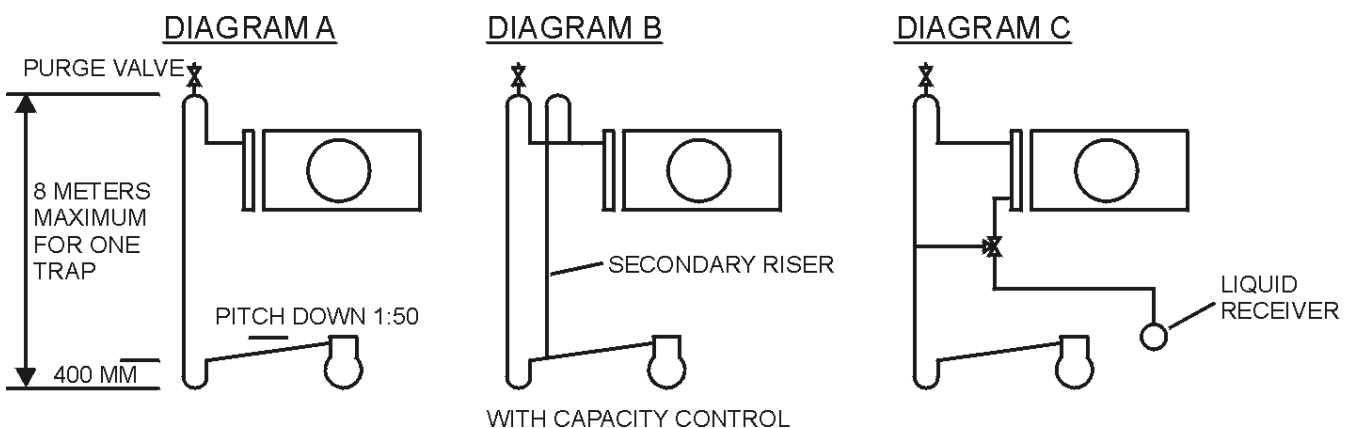

Receiver less systems are not recommended for field installed plants due to fluctuations in liquid requirements caused by varying refrigeration loadings.

The only exceptions to receiver less systems are packaged equipment or where the condenser is sufficiently oversized to permit liquid level fluctuations within the condenser tubes.

Some physical recommendations of good piping practice include the following:

Discharge lines should be arranged to ensure proper drainage of oil within the pipe. Horizontal runs should be pitched away from the compressor approximately 20mm per metre (1:50)

Since oil will drain down a vertical riser when the compressor is not operating, a trap should be provided which will prevent the oil from draining back to the compressor.

This trap can also serve to collect any liquid refrigerant that condenses in the vertical riser during the compressor off cycle.

The function of the trap is especially important where the receiver is located in a warmer location than the vertical discharge line. eg. Plant room with minimal ventilation.

The trap should be installed in the horizontal discharge line from the compressor and have a depth of approximately 400mm. Additional traps, one for every 8 metres of vertical rise, should be installed when vertical rise exceeds 8 metres. [Refer to **DIAGRAM A** above for a typical layout.]

The discharge line piping for a multiple compressor installation, where each compressor connects to a separate circuit of the condenser should be handled in the same manner as described above for a single circuit unit. In this case, a vapour purge valve must be installed at the highest point of the hot gas line of each circuit

When a remote air-cooled condenser is installed, in a system utilising capacity control, the inclusion of dual discharge risers is recommended. The main riser should be sized for the maximum system capacity less the lowest system capacity. The secondary riser should be sized for the lowest system capacity. A trap needs to be provided in the main riser in the same manner as previously described. [Refer to **DIAGRAM B** above for a typical layout.] When installing in this manner, at maximum system capacity hot gas (and oil) will flow through both risers, when operating at minimum capacity oil will trap in the main riser and hot gas will flow through the secondary riser at the required velocity.

When a pressure stabilizer is installed, the discharge line should rise above the top of the hot gas header prior to entering the coil. A purge valve should be installed at the highest point. [Refer to **DIAGRAM C** above for a typical layout]

Particular care should be taken to ensure that the necessary flexibility is incorporated into the discharge line to absorb any mechanical vibrations, emanating from the compressor. If necessary, a vibration eliminator should be installed close to the compressor. The vibration eliminator must be firmly anchored on the downstream side to a solid structure adjacent to the compressor to prevent further mechanical vibrations being transmitted down the discharge line to the condenser. It is also important to ensure that any significant refrigerant discharge gas pulsations are adequately dampened by the fitting of a suitable discharge line muffler and thus prevent pulsations from causing noise or stressful mechanical vibrations within the condenser.

LIQUID DRAIN LINES

The need to size this pipe correctly is often misunderstood. This is particularly true for modern, air-cooled condenser designs such as the Patton QAC and NQAC.

The correct sizing and installation of this line from a Patton (N)QAC is critical to obtain design performance. As mentioned earlier, these condensers are designed for zero inherent sub-cooling. This means that all of the internal surfaces of the condenser tubes are designed for permitting condensation to occur. Should liquid refrigerant be permitted to build up in the tubes for any reason (eg; restriction in the liquid drain line), then the condenser will not deliver its rated rejection. The condenser may appear to be performing well through a cool liquid outlet pipe temperature - this is actually inherent sub-cooling occurring, however at the same time higher discharge gas temperatures will result in a far higher condenser split (less overall condenser capacity).

Following ASHRAE guidelines is recommended In the case of the liquid drain line, should be designed for a minimum refrigerant velocity of 0.5 m/s. This method will permit liquid drainage by gravity. In most systems this line will need to drain into a liquid receiver with a generous inlet connection size. The pipe literally acts as a "sewer" permitting vapour to pass vertically upward at the same time as condensed liquid passes vertically downward. The receiver used in this way acts as a "surge" tank - to cater for downstream expansion devices (ie TXV) - that normally modulate to satisfy fluctuating evaporator loads.

In most "field piped" installations it would normally be impossible to avoid the use of a liquid receiver in order to achieve field rated performance. The exception would be in "factory engineered systems" or "packed equipment". In these systems, where load fluctuations are limited, condensers are sometimes oversized and refrigerant charge, (volume) is established accurately though controlled testing. Strict operating parameters are normally set by manufacturers of this equipment.

CONNECTIONS TO CONDENSER:

MODELS (N)QAC150 TO (N)QAC 400

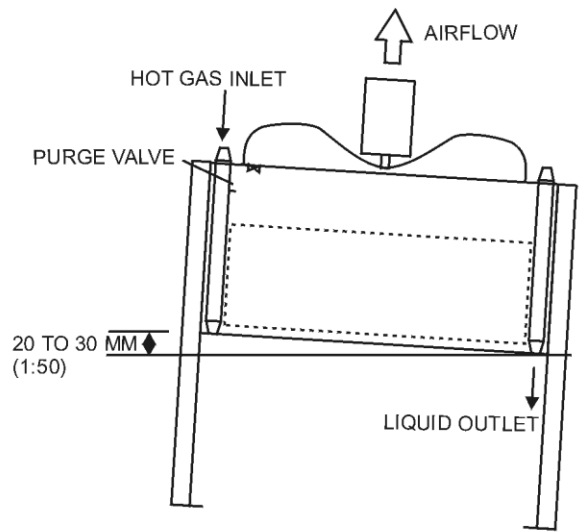
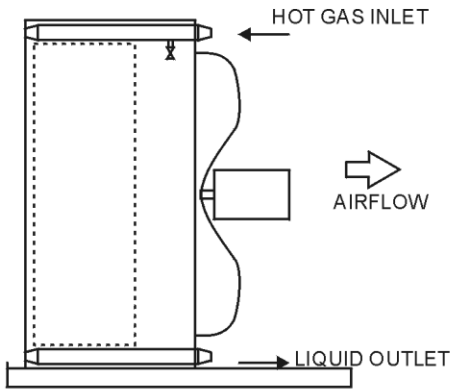

MODELS (N)QAC500 TO (N)QAC 3000

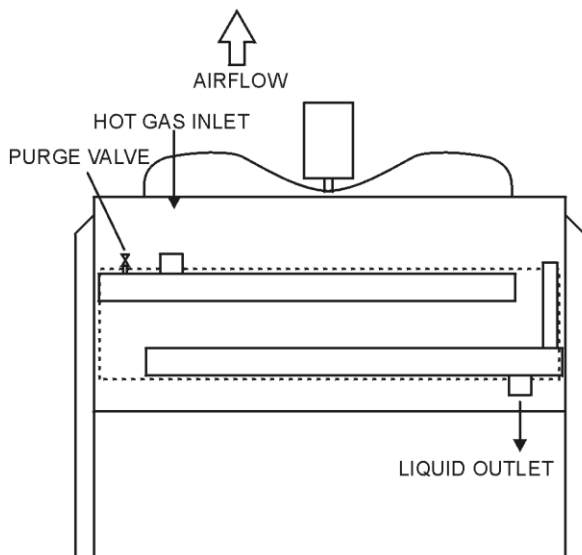
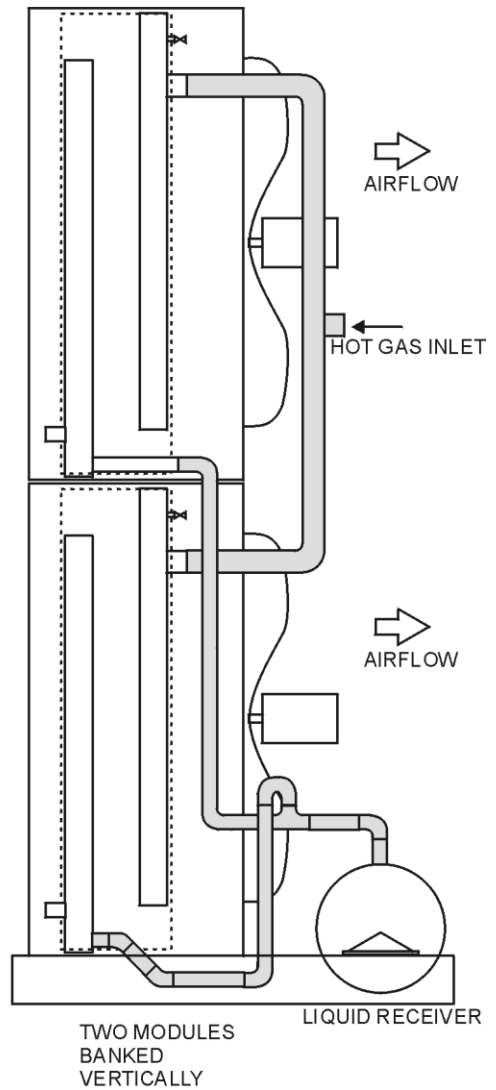
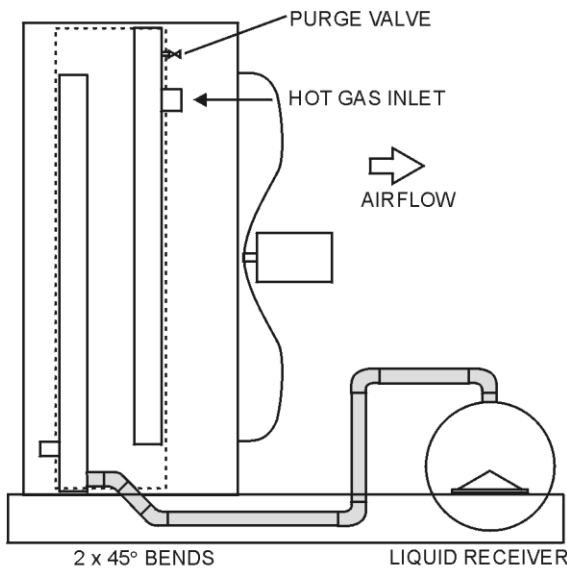

Models (N, H, S & E)QAC3500

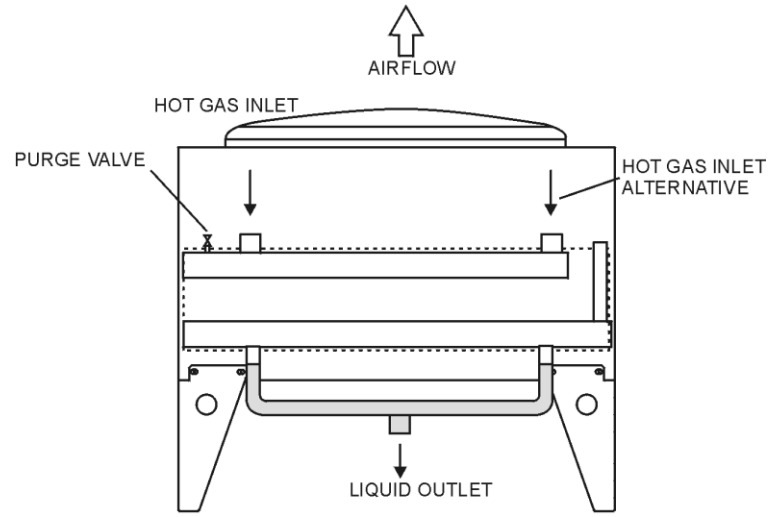
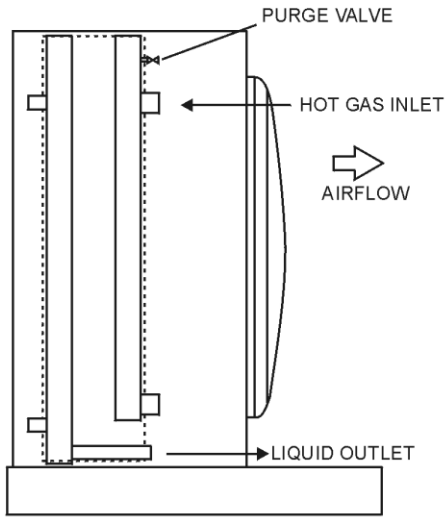

Models (N, H, S & E)QAC4000 to 7500

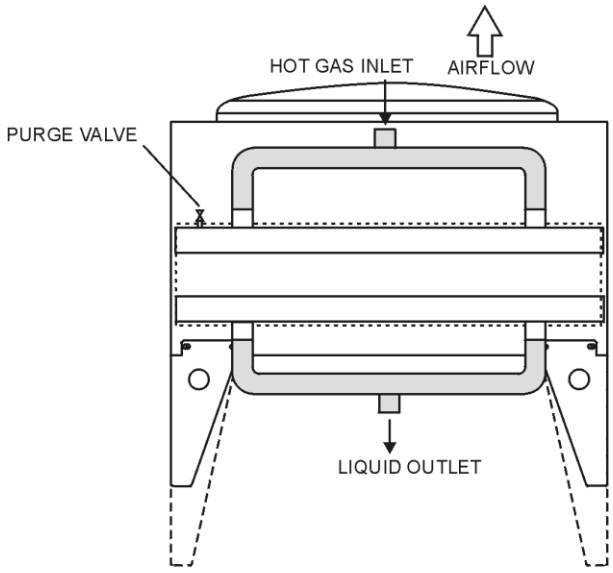

EXTENDED LEGS AVAILABLE AS AN OPTIONAL EXTRA FOR MODELS QAC & NQAC 3500 THROUGH 7500 AND MULTIPLE MODULES

TYPICAL CONNECTION FOR MULTIPLE MODULE APPLICATION:

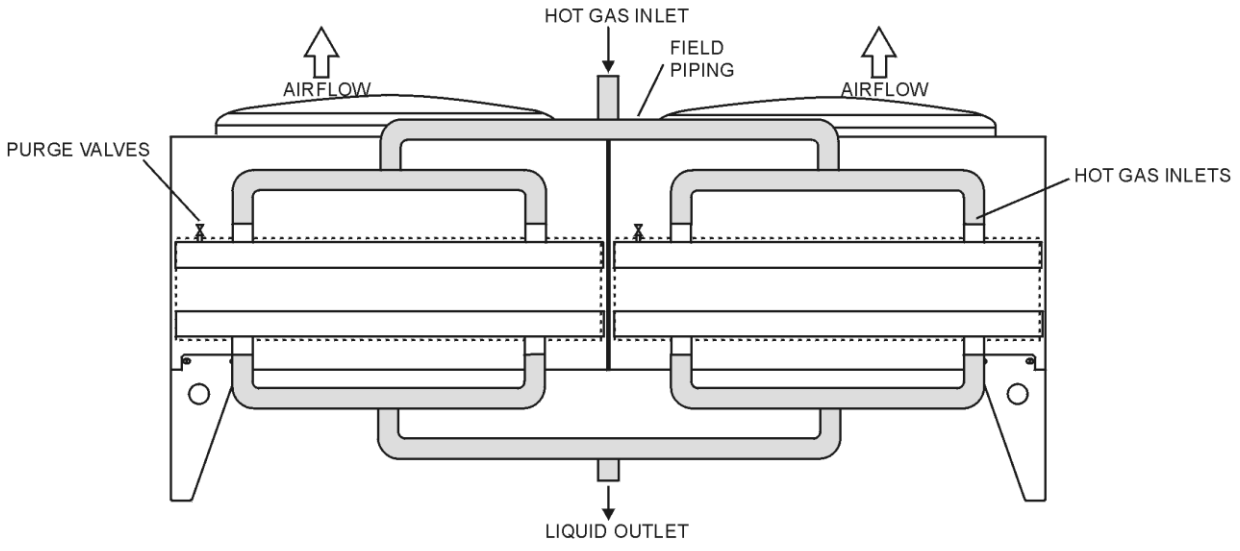

NQAC WIRING DIAGRAMS
EXTERNAL ROTOR MOTORS
SINGLE PHASE 220/240V 50Hz

PATTON REFRIGERATION LTD
AUCKLAND NEW ZEALAND

DW183
 31 MARCH 2011

MODELS NQAC 150 & 200 & 250
 1 x 350Ø FAN

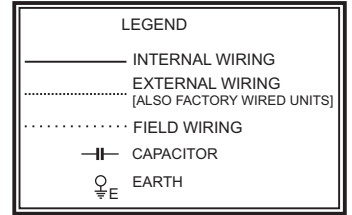
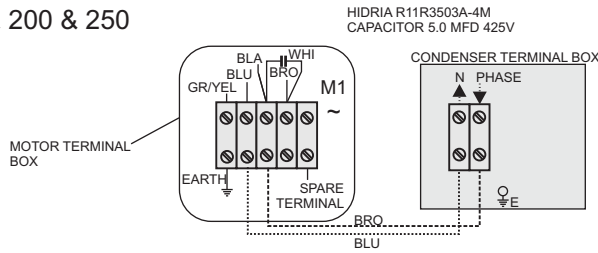

MODELS NQAC 300, 400 & 500
 2 x 350Ø FANS

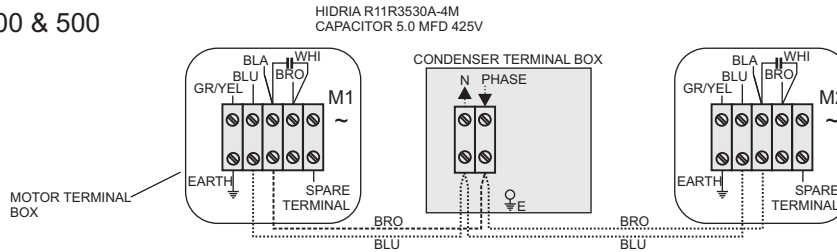

MODELS NQAC 600 & 650
 2 x 400Ø FANS

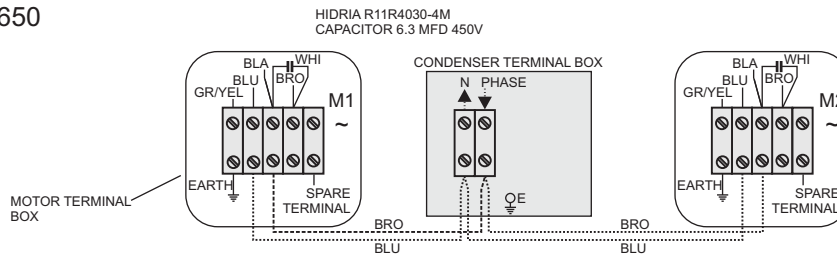

MODELS NQAC 750, 900, 1000, 1300 & 1400
 2 x 500Ø FANS

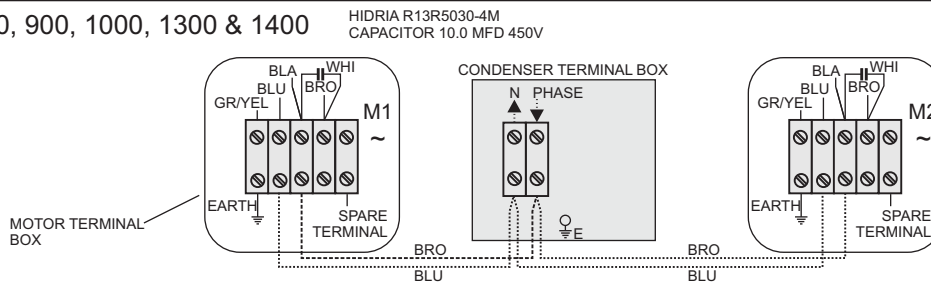

MODELS NQAC 1500, 1700, 2050 & 2400
 2 x 610Ø FANS

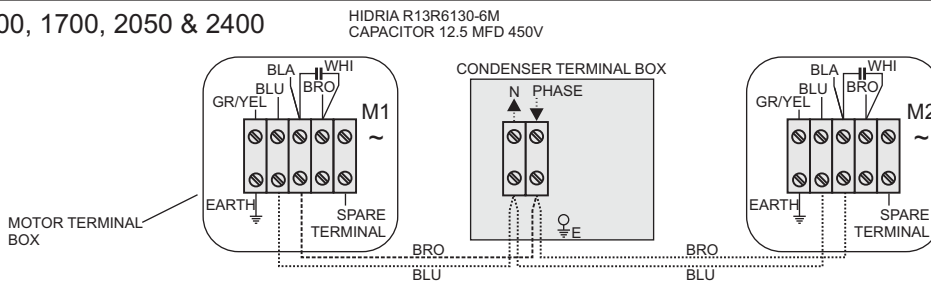

MODELS NQAC 3000
 3 x 610Ø FANS

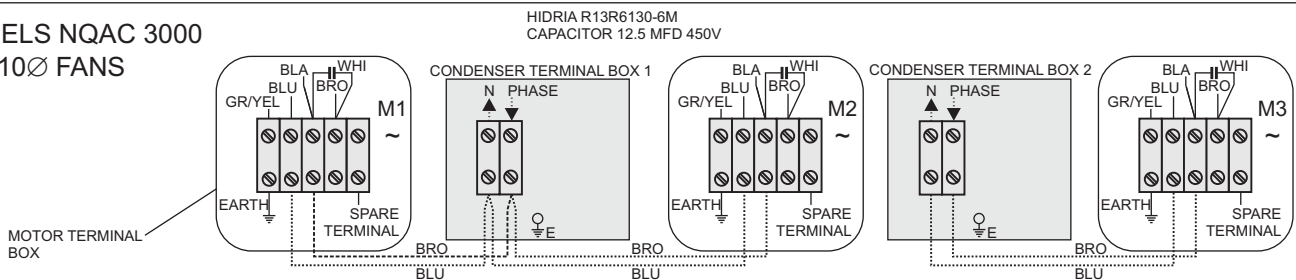

OI NQAC1Ø

CAUTION :- MOTORS HAVE AUTOMATIC INTERNAL OVERLOAD PROTECTION AND **MAY START UNEXPECTEDLY**
 PLEASE NOTE: THIS WIRING DIAGRAM IS PROVIDED FOR APPLICATION ASSISTANCE AND MAY NOT BE USED FOR CLAIMS AGAINST THE COMPANY.

WARNING : THIS DRAWING IS THE PROPERTY OF PATTON REFRIGERATION LTD AND MAY NOT BE REPRODUCED IN ANY FORM WITHOUT THE WRITTEN PERMISSION OF THE COMPANY

(N)QAC WIRING DIAGRAMS
THREE PHASE MOTORS
380/420V 50Hz

PATTON LTD

DW187

6 JULY 2006

MODELS QAC 3500 - 7500
 HIGH SPEED DELTA (Δ)

MOTOR : CMG ~ CWC 3945A

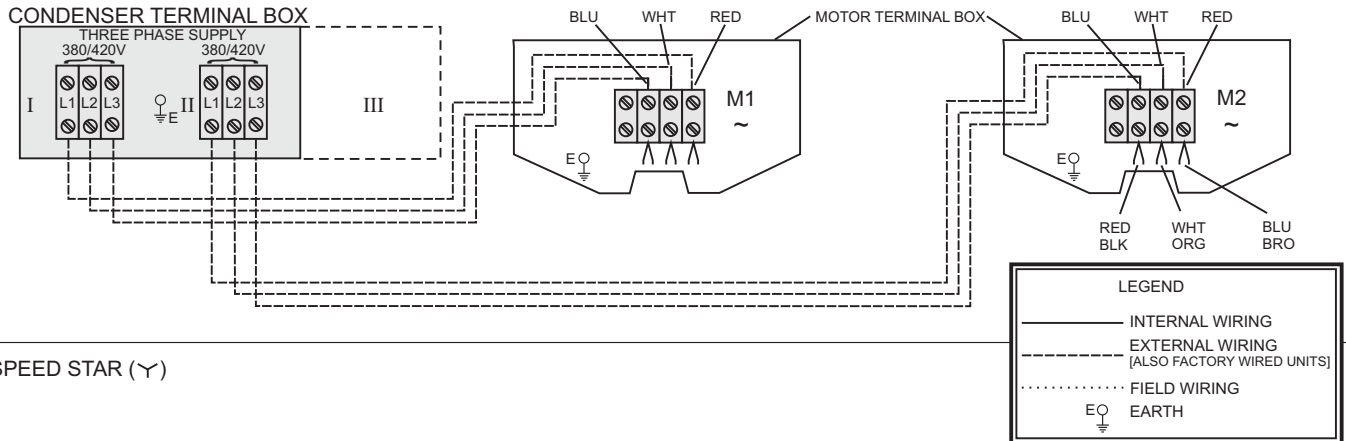

LOW SPEED STAR (Υ)

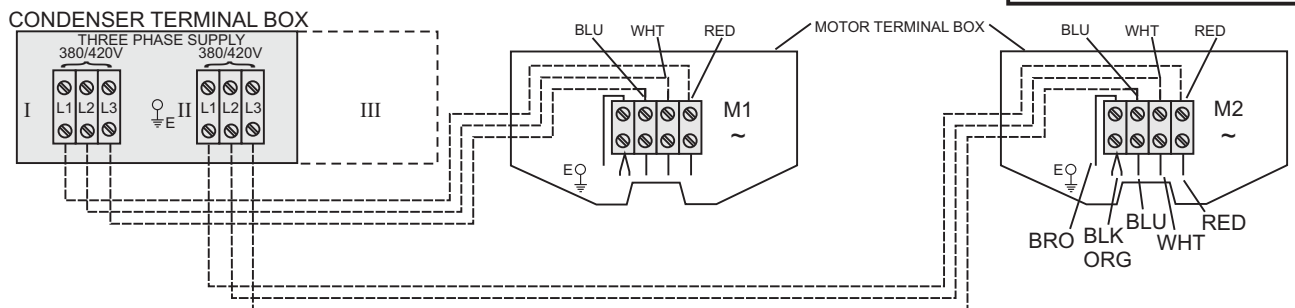

CAUTION : MOTORS HAVE AUTOMATIC INTERNAL OVERLOAD PROTECTION AND MAY START UNEXPECTEDLY

MODELS NQAC 3500 - 7500
 HIGH SPEED DELTA (Δ)

MOTOR : HIDRIA ~ R18E-8030HA-8T

INTERNAL THERMAL OVERLOAD PROTECTION
 MAX 2.5A 220/240V

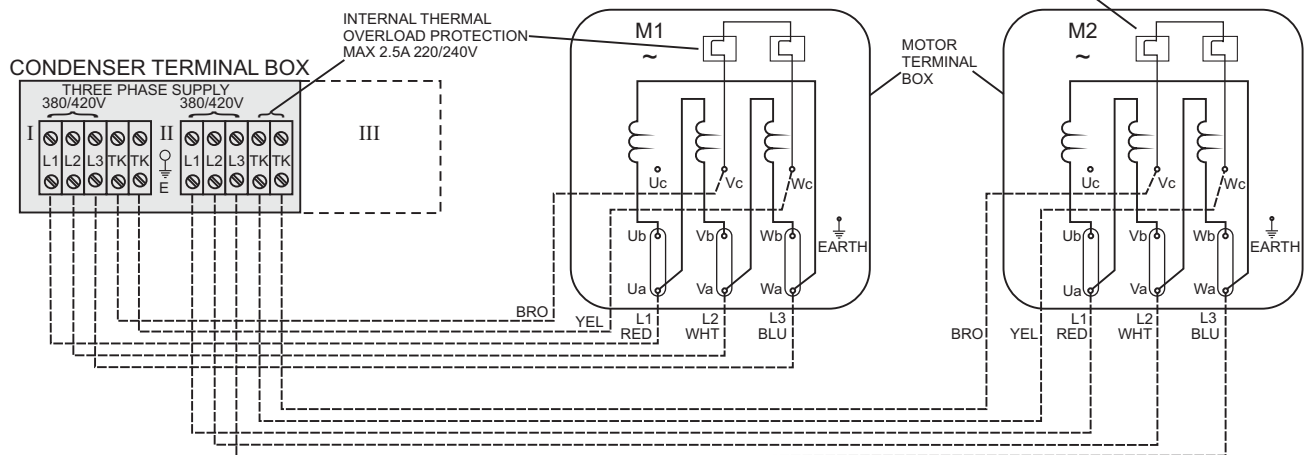

LOW SPEED STAR (Υ)

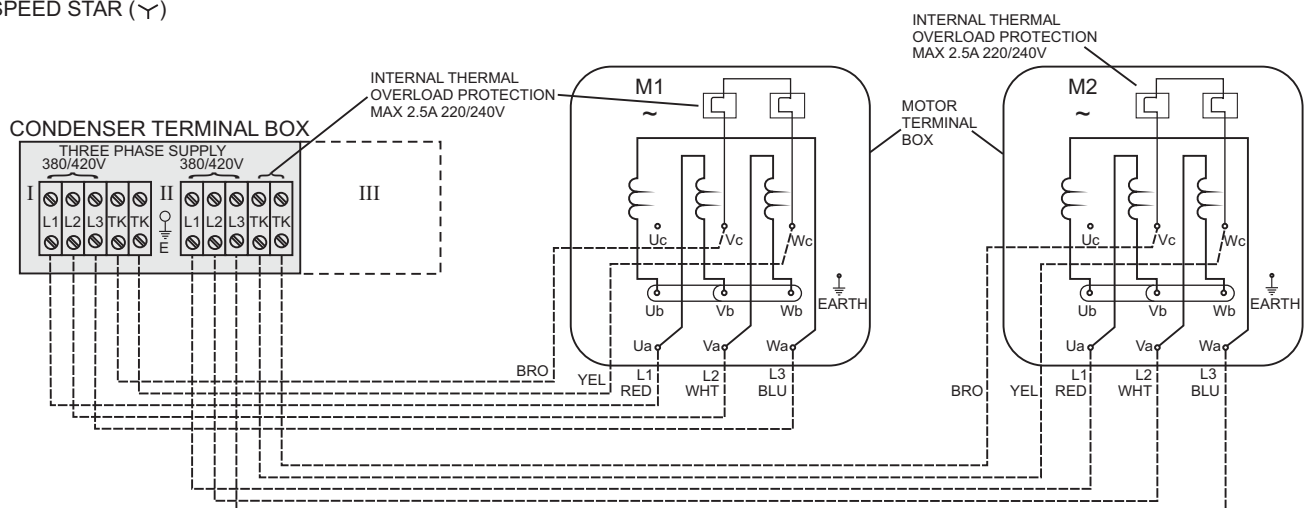

Please Note: This wiring diagram is provided for application assistance and may not be used for claims against the Company.

