

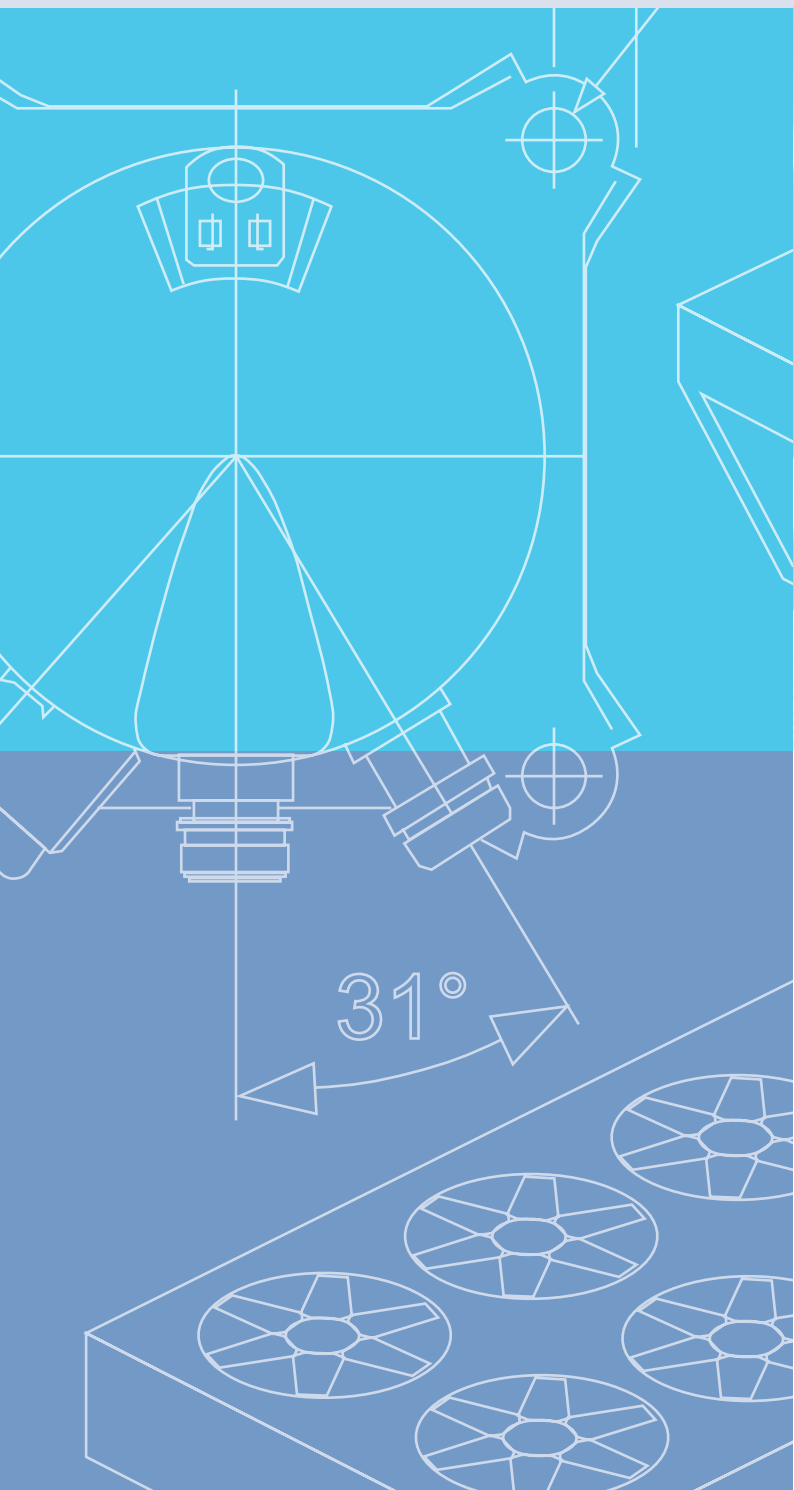

Scroll Compressors for Air Conditioning

ZR18K* to ZR380K*, ZP24K* to ZP485K*



1	Safety instructions	1
1.1	Icon explanation	1
1.2	Safety statements	1
1.3	General instructions	2
2	Product description	3
2.1	Common information about Copeland Scroll™ compressors.....	3
2.2	About this guideline.....	3
2.3	Nomenclature.....	3
2.4	Application range	3
2.4.1	<i>Qualified refrigerants and oils</i>	3
2.4.2	<i>Application limits</i>	4
3	Installation	5
3.1	Compressor handling.....	5
3.1.1	<i>Transport and storage</i>	5
3.1.2	<i>Positioning and securing</i>	5
3.1.3	<i>Installation location</i>	5
3.1.4	<i>Mounting parts</i>	5
3.2	Brazing procedure.....	6
3.3	Shut-off valves and adaptors	7
3.4	Accumulators	8
3.5	Screens	9
3.6	Mufflers	9
3.7	Reversing valves.....	9
3.8	Suction line noise and vibration	9
4	Electrical connection	11
4.1	General recommendations.....	11
4.2	Electrical installation	11
4.2.1	<i>Terminal box</i>	13
4.2.2	<i>Motor winding</i>	13
4.2.3	<i>Protection devices</i>	14
4.2.4	<i>Crankcase heaters</i>	14
4.3	Pressure safety controls	14
4.3.1	<i>High-pressure control</i>	14
4.3.2	<i>Low-pressure control</i>	15
4.3.3	<i>Internal pressure relief valve</i>	15
4.4	Discharge temperature protection	15
4.5	Motor protection	16
4.6	Protector functional check and failure detection.....	17
4.7	High-potential testing	18
5	Starting up & operation.....	19



5.1	Strength pressure test.....	19
5.2	Tightness/pressure test.....	19
5.3	Preliminary checks – Pre-starting	19
5.4	Charging procedure	19
5.5	Initial start-up	20
5.6	Rotation direction	20
5.7	Starting sound.....	20
5.8	Deep vacuum operation.....	20
5.9	Shell temperature.....	21
5.10	Pump down cycle	21
5.11	Minimum run time	21
5.12	Shut-off sound.....	21
6	Maintenance & repair	22
6.1	Exchanging the refrigerant.....	22
6.2	Rotalock valves.....	22
6.3	Replacing a compressor	22
6.3.1	Compressor replacement.....	22
6.3.2	Start-up of a new or replacement compressor.....	22
6.4	Lubrication and oil removal	23
6.5	Unbrazing system components	23
7	Dismantling & disposal.....	24

1 Safety instructions







Copeland Scroll™ compressors are manufactured according to the latest European and US Safety Standards. Particular emphasis has been placed on the user's safety.

These compressors are intended for installation in systems according to the EC Machines directive. They may be put to service only if they have been installed in these systems according to instructions and conform to the corresponding provisions of legislation. For relevant standards please refer to Manufacturers Declaration, available on request.

These instructions should be retained throughout the lifetime of the compressor.

You are strongly advised to follow these safety instructions.

1.1 Icon explanation

 <p>WARNING This icon indicates instructions to avoid personal injury and material damage.</p>	 <p>CAUTION This icon indicates instructions to avoid property damage and possible personal injury.</p>
 <p>High voltage This icon indicates operations with a danger of electric shock.</p>	 <p>IMPORTANT This icon indicates instructions to avoid malfunction of the compressor.</p>
 <p>Danger of burning or frostbite This icon indicates operations with a danger of burning or frostbite.</p>	<p>NOTE This word indicates a recommendation for easier operation.</p>
 <p>Explosion hazard This icon indicates operations with a danger of explosion.</p>	

1.2 Safety statements

- Refrigerant compressors must be employed only for their intended use.
- Only qualified and authorized HVAC or refrigeration personnel are permitted to install, commission and maintain this equipment.
- Electrical connections must be made by qualified electrical personnel.
- All valid standards for connecting electrical and refrigeration equipment must be observed.



Use personal safety equipment. Safety goggles, gloves, protective clothing, safety boots and hard hats should be worn where necessary.



1.3 General instructions



WARNING

System breakdown! Personal injuries! Never install a system in the field and leave it unattended when it has no charge, a holding charge, or with the service valves closed without electrically locking out the system.

System breakdown! Personal injuries! Only approved refrigerants and refrigeration oils must be used.



WARNING

High shell temperature! Burning! Do not touch the compressor until it has cooled down. Ensure that other materials in the area of the compressor do not get in touch with it. Lock and mark accessible sections.



CAUTION

Overheating! Bearing damage! Do not operate compressors without refrigerant charge or without being connected to the system.



IMPORTANT

Transit damage! Compressor malfunction! Use original packaging. Avoid collisions and tilting.

2 Product description

2.1 Common information about Copeland Scroll™ compressors

The Scroll compressor has been under development at Emerson Climate Technologies since 1979. It is the most efficient and durable compressor Emerson Climate Technologies has ever developed for air conditioning and refrigeration.

This application guideline deals with all vertical single Copeland Scroll™ compressors for air conditioning and heat pump applications, from ZR18K* to ZR380K* and from ZP24K* to ZP485K*. These compressors have one Scroll compression set driven by a single or three-phase induction motor. The Scroll set is mounted at the upper end of the rotor shaft of the motor. The rotor shaft axis is in the vertical plane.

2.2 About this guideline

This guideline is intended to enable users to ensure the safe installation, starting, operation and maintenance of the Scroll compressors. It is not intended to replace the system expertise available from system manufacturers.

2.3 Nomenclature

The model designation contains the following technical information about the compressor:

ZR 380K C E - TWD - 522

Bill of material number
Motor version
Oil type: E = POE oil; Blank = Mineral oil
Model variation
Nominal capacity [BTU/h] @ 60 Hz and ARI conditions
Refrigerant(s): R = R407C, R134a, R22 P = R410A
Compressor family: Z = Scroll

*ARI-Conditions:

Evaporating temperature	7.2°C	Liquid sub-cooling	8.3 K
Condensing temperature	54.4°C	Ambient temperature	35°C
Suction gas superheat	11 K		

2.4 Application range

2.4.1 Qualified refrigerants and oils



IMPORTANT

It is essential that the glide of refrigerant blends (primarily R407C) is carefully considered when adjusting pressure and superheat controls.

Oil recharge values can be taken from Copeland Scroll™ compressors brochures or Copeland® Brand Products Selection Software.

Qualified refrigerants	R22	R407C, R134a, R22	R410A
Copeland® Brand Products standard oil	White oil / Suniso 3 GS	Emkarate RL 32 3MAF	
Servicing oil	Suniso 3 GS / White oil	Emkarate RL 32 3MAF	
		Mobil EAL Arctic 22 CC	

Table 1: Qualified refrigerants and oils

2.4.2 Application limits

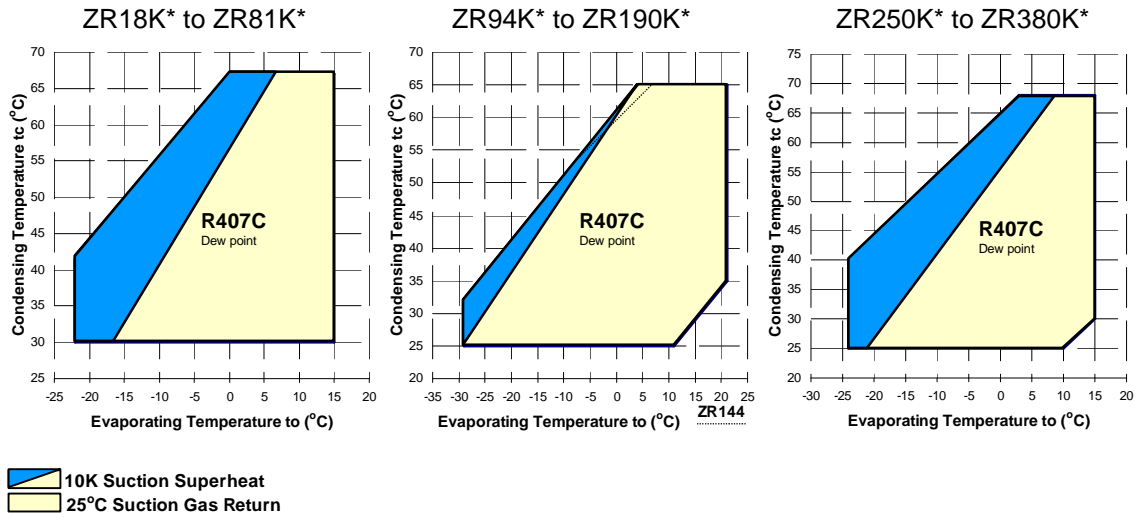

Figure 1: Application envelopes for compressors ZR18K* to ZR380K* with R407C

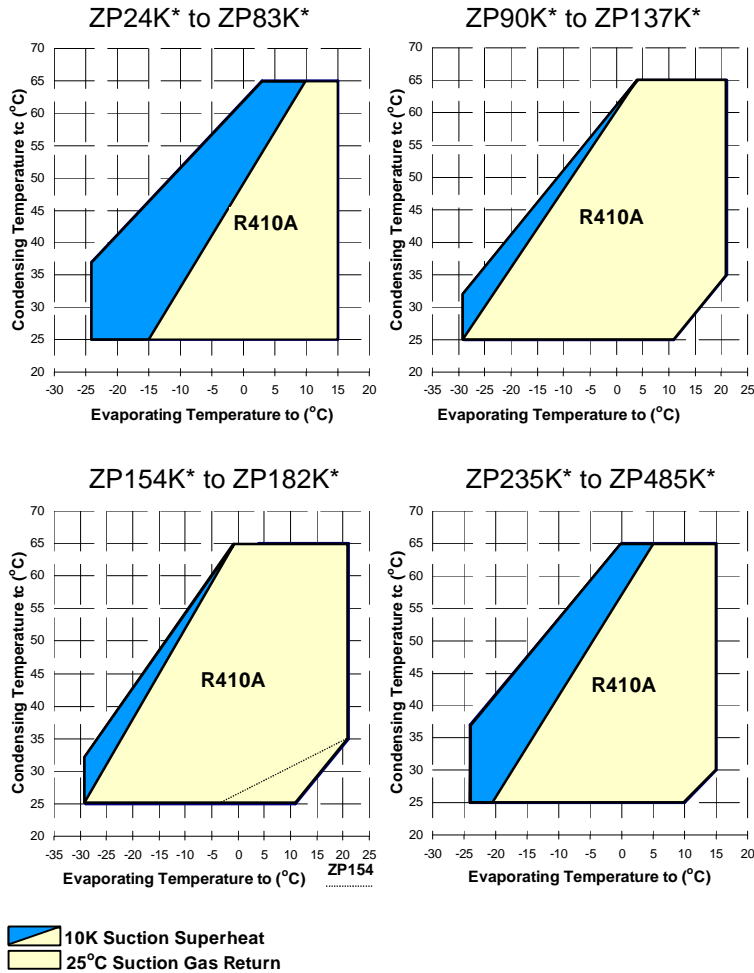

Figure 2: Application envelopes for compressors ZP24K* to ZP485K* with R410A

NOTE: For application envelopes with R134a and R22, please refer to Copeland® Brand Products Selection Software.

3 Installation



WARNING

High pressure! Injury to skin and eyes possible! Be careful when opening connections on a pressurized item.

3.1 Compressor handling

3.1.1 Transport and storage



WARNING

Risk of collapse! Personal injuries! Move compressors only with appropriate mechanical or handling equipment according to weight. Keep in the upright position. Stack pallets on top of each other when not exceeding 300 kg. Do not stack single boxes on top of each other. Keep the packaging dry at all times.

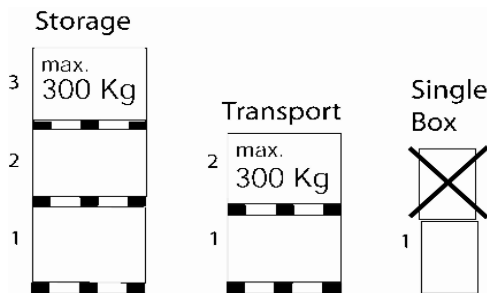

Figure 3

3.1.2 Positioning and securing



IMPORTANT

Handling damage! Compressor malfunction! Only use the lifting eyes whenever the compressor requires positioning. Using discharge or suction connections for lifting may cause damage or leaks.

For models ZR94K* to ZR190K* and ZP90K* to ZP182K*, because oil might spill out of the suction connection located low on the shell, the suction connection plug must be left in place until the compressor is set into the unit. If possible, the compressor should be kept vertical during handling. The discharge connection plug should be removed first before pulling the suction connection plug to allow the dry air pressure inside the compressor to escape. Pulling the plugs in this sequence prevents oil mist from coating the suction tube making brazing difficult. The copper coated steel suction tube should be cleaned before brazing. No object, eg, a swaging tool should be inserted deeper than 51 mm into the suction tube or it might damage the suction screen and motor.

3.1.3 Installation location

Ensure the compressors are installed on a solid level base.

3.1.4 Mounting parts

Four vibration absorber grommets are supplied with each compressor. They dampen the start-up surge of the compressor and minimise sound and vibration transmission to the compressor base during operation. The metal sleeve inside is a guide designed to hold the grommet in place. It is not designed as a load-bearing member, and application of excessive torque to the bolts can crush the sleeve. Its inner diameter is approximately 8.5 mm to fit, eg, an M8 screw. The mounting torque should be 13 ± 1 Nm. It is critically important that the grommet is not compressed. A clearance space of approximately 2 mm between the bottom of the washer and the top of the grommet spacer is recommended.

If the compressors are mounted in tandem or used in parallel, then the hard mountings (bolt M9 5/16") are recommended. The mounting torque should be 27 ± 1 Nm. It is possible to deliver these hard mounting parts as a kit, or on request to deliver the compressor with these parts instead of the rubber grommets.

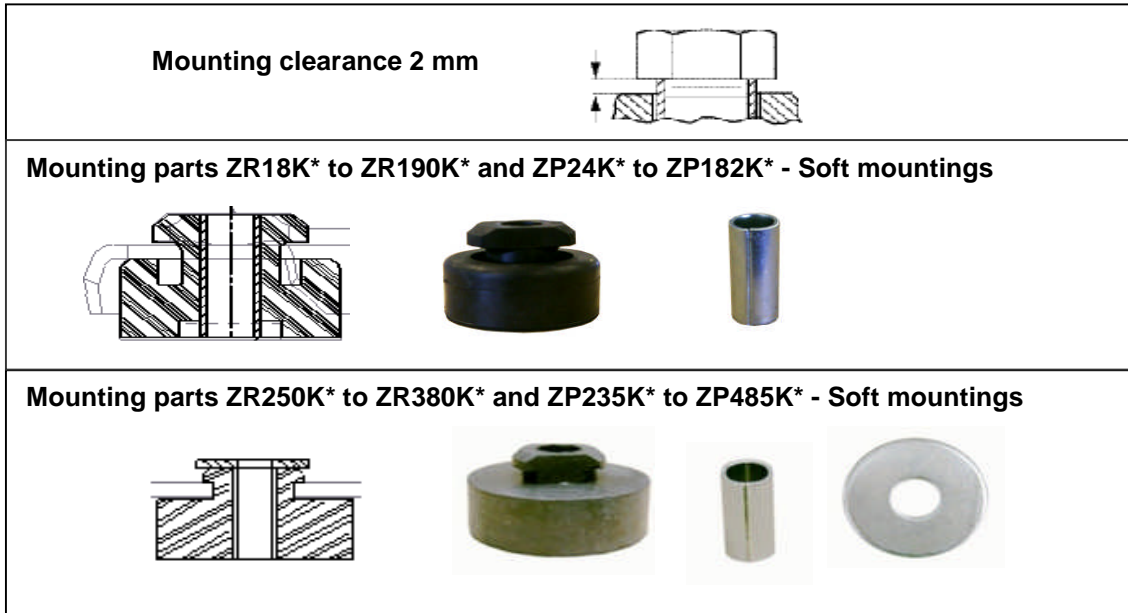

Figure 4

3.2 Brazing procedure

IMPORTANT

Blockage! Compressor breakdown! Maintain a flow of oxygen-free nitrogen through the system at very low pressure during brazing. Nitrogen displaces the air and prevents the formation of copper oxides in the system. If allowed to form, the copper oxide material can later be swept through the system and block screens such as those protecting capillary tubes, thermal expansion valves, and accumulator oil return holes.

Contamination or moisture! Bearing failure! Do not remove the plugs until the compressor is set into the unit. This minimises any entry of contaminants and moisture.

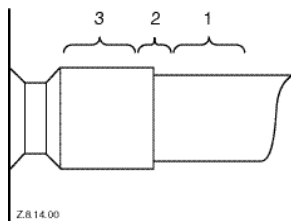

Figure 5: Suction tube brazing

Copeland Scroll™ compressors have copper-plated steel suction and discharge tubes. These tubes are far more robust and less prone to leaks than copper tubes. Due to the different thermal properties of steel and copper, brazing procedures may have to be changed from those commonly used.

Figure 5 shows the proper procedures for brazing the suction and discharge lines to a scroll compressor.

- The copper-coated steel tubes on scroll compressors can be brazed in approximately the same manner as any copper tube. Recommended brazing materials: any silfos material is recommended, preferably with a minimum of 5% silver. However, 0% silver is acceptable.
- Be sure tube fitting inner diameter and tube outer diameter are clean prior to assembly.
- Using a double-tipped torch, apply heat in area 1.
- As the tube approaches brazing temperature, move the torch flame to area 2.
- Heat area 2 until braze temperature is attained, moving the torch up and down and rotating around the tube as necessary to heat the tube evenly. Add braze material to the joint while moving the torch around the joint to flow braze material around the circumference.
- After the braze material flows around the joint, move the torch to heat area 3. This will draw the braze material down into the joint. The time spent heating area 3 should be minimal.
- As with any brazed joint, overheating may be detrimental to the final result.

To disconnect:

- Heat joint areas 2 and 3 slowly and uniformly until the braze material softens and the tube can be pulled out of the fitting.

To reconnect:

- Recommended brazing materials: Silfos with minimum 5% silver or silver braze used on other compressors. Due to the different thermal properties of steel and copper, brazing procedures may have to be changed from those commonly used.

NOTE: Since the discharge stub contains a check valve, care must be taken not to overheat it to prevent brazing material to flow into it.

3.3 Shut-off valves and adaptors



CAUTION

Leaking system! System breakdown! It is strongly recommended to periodically re-torque all pipe and fixing connections to the original setting after the system has been put into operation.

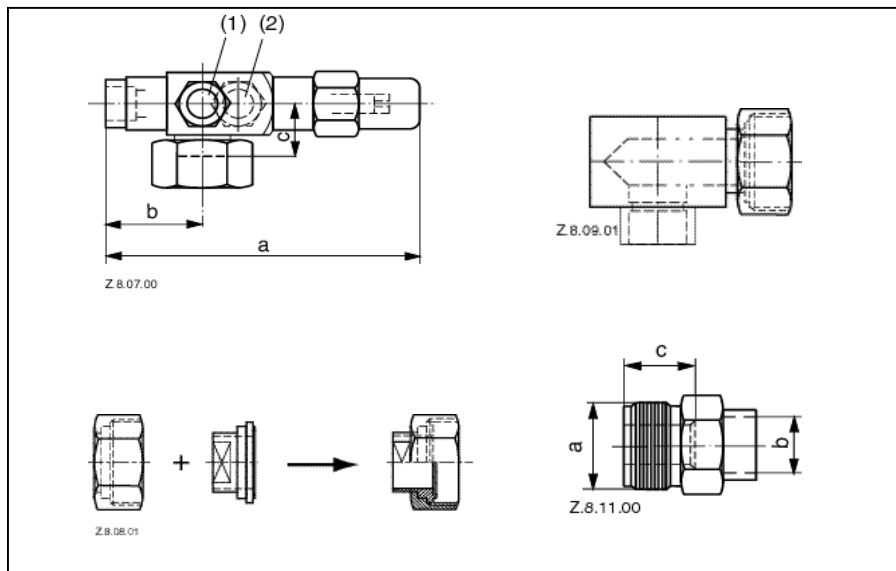

Figure 6

Copeland Scroll™ compressors are delivered with a discharge check valve fitted inside the discharge port and rubber plugs fitted to the suction and discharge ports as standard. There are options to fit either Rotalock valves, or Rotalock adaptors or just make brazing connections.

Braze connections can be converted to Rotalock by means of adaptors. Rotalock shut-off valves are available for the suction as well as discharge sides. Using either straight or angled adaptors provides a way to convert a Rotalock into a brazing connection.

Refer to the following table for proper tightening torques:

	Torque [Nm]
Rotalock 3/4"-16UNF	40-50
Rotalock 1"-14UNF	70-80
Rotalock 1 1/4"-12UNF	110-135
Rotalock 1 3/4"-12UNF	135-160
Rotalock 2 1/4"-12UNF	165-190

Table 2

NOTE: More information concerning adaptors and shut-off valves can be found in the "Spare parts list".

3.4 Accumulators



CAUTION

Inadequate lubrication! Bearing destruction! Minimise liquid refrigerant returning to the compressor. Too much refrigerant dilutes the oil. Liquid refrigerant can wash the oil off the bearings leading to overheating and bearing failure.

Due to Copeland Scroll™ compressors inherent ability to handle liquid refrigerant in flooded start and defrost cycle operation, an accumulator is not required for durability in most systems. However, large volumes of liquid refrigerant repeatedly flooding back to the compressor during normal off cycles, or excessive liquid refrigerant flooding back during defrost or varying loads, can dilute the oil, no matter what the system charge is. As a result, bearings will be inadequately lubricated and wear may occur.

To determine if the accumulator can be removed, dedicated tests must be carried out to ensure that excessive liquid does not flood back to the compressor during defrost or varying loads. The defrost test must be done at an outdoor ambient temperature of around 0°C in a high humidity environment. Liquid floodback must be monitored during reversing valve operation, especially when coming out of defrost. Excessive floodback occurs when the sump temperature drops below the safe operation line shown in **Figure 7** for more than 10 seconds.

If an accumulator must be used, the oil-return orifice should be from 1 to 1.4 mm in diameter for models ZR18K* to ZR81K* and ZP24K* to ZP83K*, and 2.0 mm for models ZR94K* to ZR380K* and ZP90K* to ZP485K*, depending on compressor size and compressor flood back results. A large-area protective screen no finer than 30 x 30 mesh (0.6 mm openings) is required to protect this small orifice from plugging with system debris. Tests have shown that a small screen with a fine mesh can easily become plugged causing oil starvation to the compressor bearings.

The size of the accumulator depends upon the operating range of the system and the amount of subcooling and subsequent head pressure allowed by the refrigerant control. System modelling indicates that heat pumps that operate down to and below -18°C will require an accumulator that can hold around 70% to 75% of the system charge.

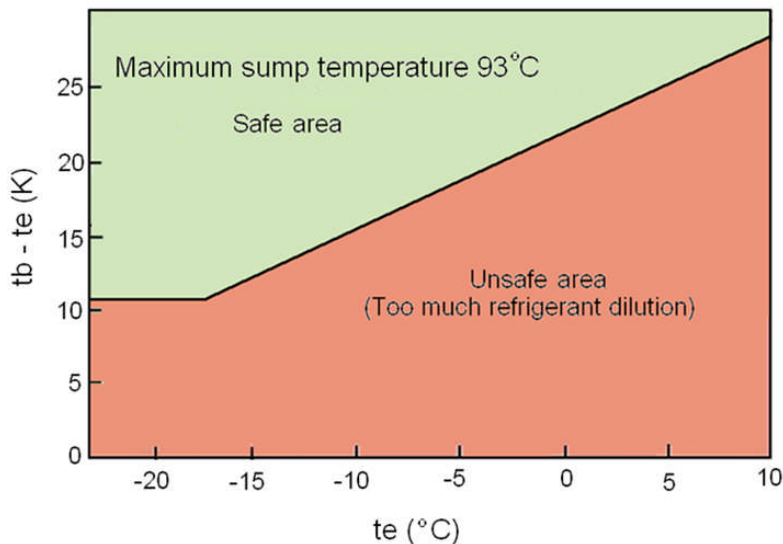

Figure 7: Dilution chart for transient operation (t_b = bottom shell temperature; t_e = evaporating temperature)

3.5 Screens



CAUTION

Screen blocking! Compressor breakdown! Use screens with at least 0.6 mm openings.

The use of screens finer than 30 x 30 mesh (0.6 mm openings) anywhere in the system should be avoided with these compressors. Field experience has shown that finer mesh screens used to protect thermal expansion valves, capillary tubes or accumulators can become temporarily or permanently plugged with normal system debris and block the flow of either oil or refrigerant to the compressor. Such blockage can result in compressor failure.

3.6 Mufflers

External mufflers, normally applied to piston compressors in the past, may not be required for Copeland Scroll™ compressors.

Individual system tests should be performed to verify acceptability of sound performance. If adequate attenuation is not achieved, use a muffler with a larger cross-sectional area to inlet area ratio. A ratio of 20:1 to 30:1 is recommended.

A hollow shell muffler will work quite well. Locate the muffler at minimum 15 to maximum 45 cm from the compressor for the most effective operation. The farther the muffler is placed from the compressor within these ranges, the more effective. Choose a muffler with a length of 10 to 15 cm.

3.7 Reversing valves

Since Copeland Scroll™ compressors have a very high volumetric efficiency, their displacements are lower than those of equivalent capacity reciprocating compressors. As a result, Emerson Climate Technologies recommends that the capacity rating on reversing valves be no more than 1.5 to 2 times the nominal capacity of the compressor in order to ensure proper operation of the reversing valve under all operating conditions.

The reversing valve solenoid should be wired so that the valve does not reverse when the system is shut off by the operating thermostat in the heating or cooling mode. If the valve is allowed to reverse at system shut off, suction and discharge pressures are reversed to the compressor. This results in a condition of system pressures equalising through the compressor which can cause the compressor to slowly rotate until the pressures equalise. This condition does not affect compressor durability but can cause unexpected sound after the compressor is turned off.

3.8 Suction line noise and vibration

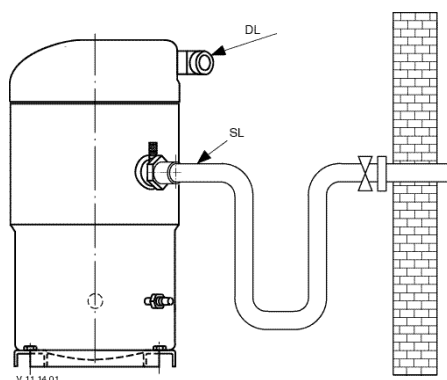

Figure 8: Suction tube design

Copeland Scroll™ compressors inherently have low sound and vibration characteristics. However in some respects the sound and vibration characteristics differ from reciprocating compressors and in rare instances could result in unexpected sound generation. One difference is that the vibration characteristic of the Scroll compressor, although low, includes two very close frequencies, one of which is normally isolated from the shell by the suspension of an internally-suspended compressor. These frequencies, which are present in all compressors, may result in a low-level "beat" frequency that can be detected as noise coming along the suction line into the building under some conditions. Elimination of the beat can be achieved by attenuating either of the contributing frequencies. This is easily done by using one of

the common combinations of recommended design configurations. The scroll compressor makes both a rocking and twisting motion and enough flexibility must be provided in the line to prevent



vibration transmission into any lines attached to the unit. In a split system, the most important goal is to ensure minimal vibration in all directions at the service valve to avoid transmitting vibrations to the structure to which the lines are fastened.

A second difference of the Copeland Scroll is that under some conditions the normal rotational starting motion of the compressor can transmit an "impact" noise along the suction line. This may be particularly pronounced in three-phase models due to their inherently higher starting torque. This phenomenon, like the one described previously, also results from the lack of internal suspension and can be easily avoided by using standard suction line isolation techniques as described below. The sound phenomena described above are not usually associated with reversible heat pump systems because of the isolation and attenuation provided by the reversing valve and tubing bends.

Recommended configuration

- Tubing configuration: small shock loop
- Service valve: "angled valve" fastened to unit / wall
- Suction muffler: not required

Alternative configuration

- Tubing configuration: small shock loop
- Service valve: "straight through" valve fastened to unit / wall
- Suction muffler: may be required (acts as dampening mass)

4 Electrical connection

4.1 General recommendations

The compressor terminal box has a wiring diagram on the inside of its cover. Before connecting the compressor, ensure the supply voltage, the phases and the frequency match the nameplate data.

4.2 Electrical installation

Recommended wiring diagrams are shown in figures hereunder.

NOTE: We recommend using a contactor K2 for the safety chain in order to comply with EN 60335.

Single-phase (PF*) compressors:

Power circuit

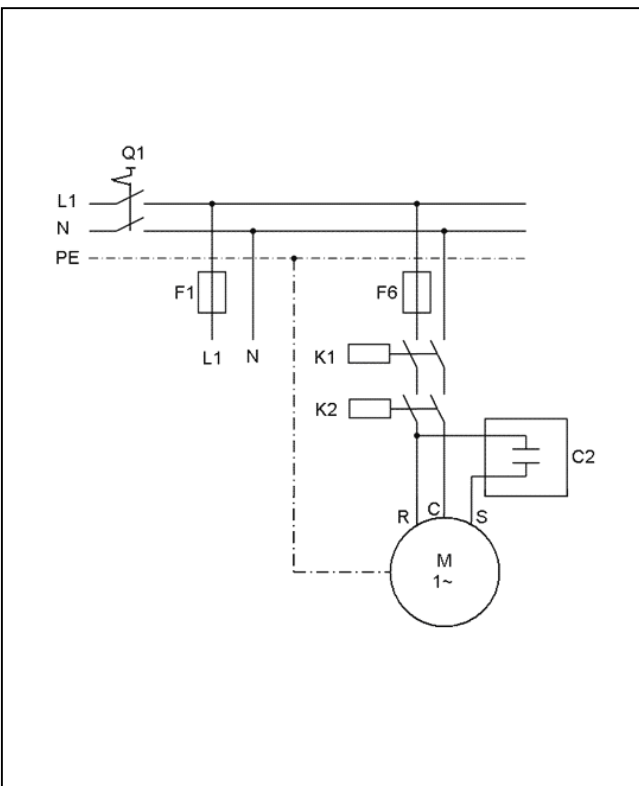

Control circuit

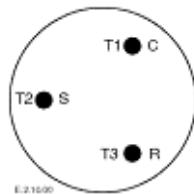
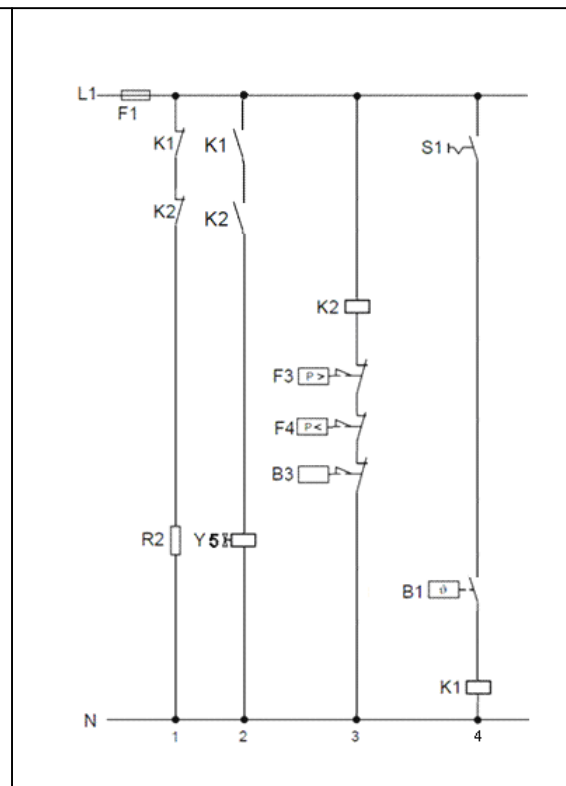

Motor terminal connections

Single-phase compressors are connected to the Common (C), Start (S) and Run (R) connections

Legend

B1	Room thermostat	K1, K2	Contactors
B3	Discharge gas thermostat	Q1	Main switch
C2	Run capacitor	R2	Crankcase heater
F1, F6	Fuses	S1	Auxiliary switch
F3	HP switch		
F4	LP switch		

Figure 9

Three-phase compressors (TF*) with internal motor protection:

Power circuit

Control circuit

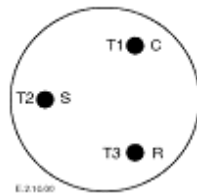
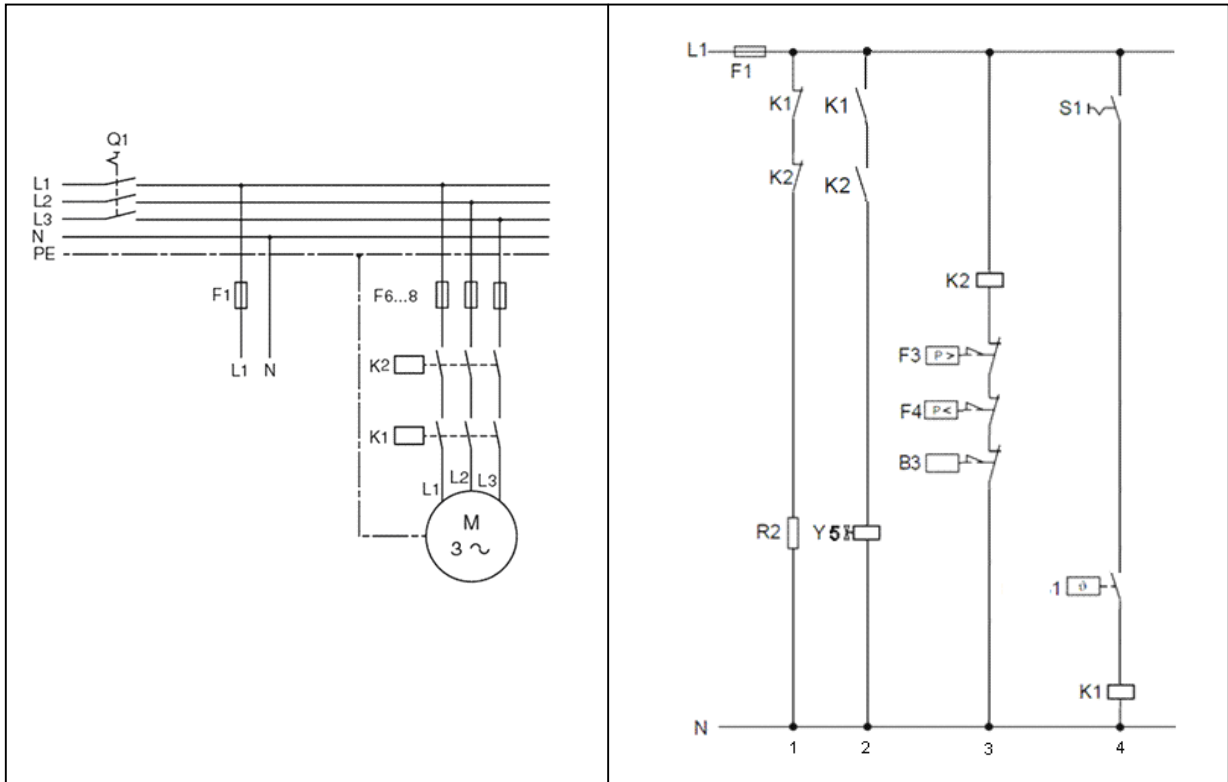

Motor terminal connections

Three-phase compressors are connected to the T1, T2 and T3 connections

Legend

- | | | | |
|------------|--------------------------|--------|------------------|
| B1 | Room thermostat | K1, K2 | Contactors |
| B3 | Discharge gas thermostat | Q1 | Main switch |
| F1, F6, F8 | Fuses | R2 | Crankcase heater |
| F3 | HP switch | S1 | Auxiliary switch |
| F4 | LP switch | | |

Figure 10

Three-phase compressors (TW*) with external motor protection INT69SC2:

Power circuit

Control circuit

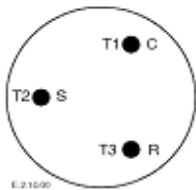
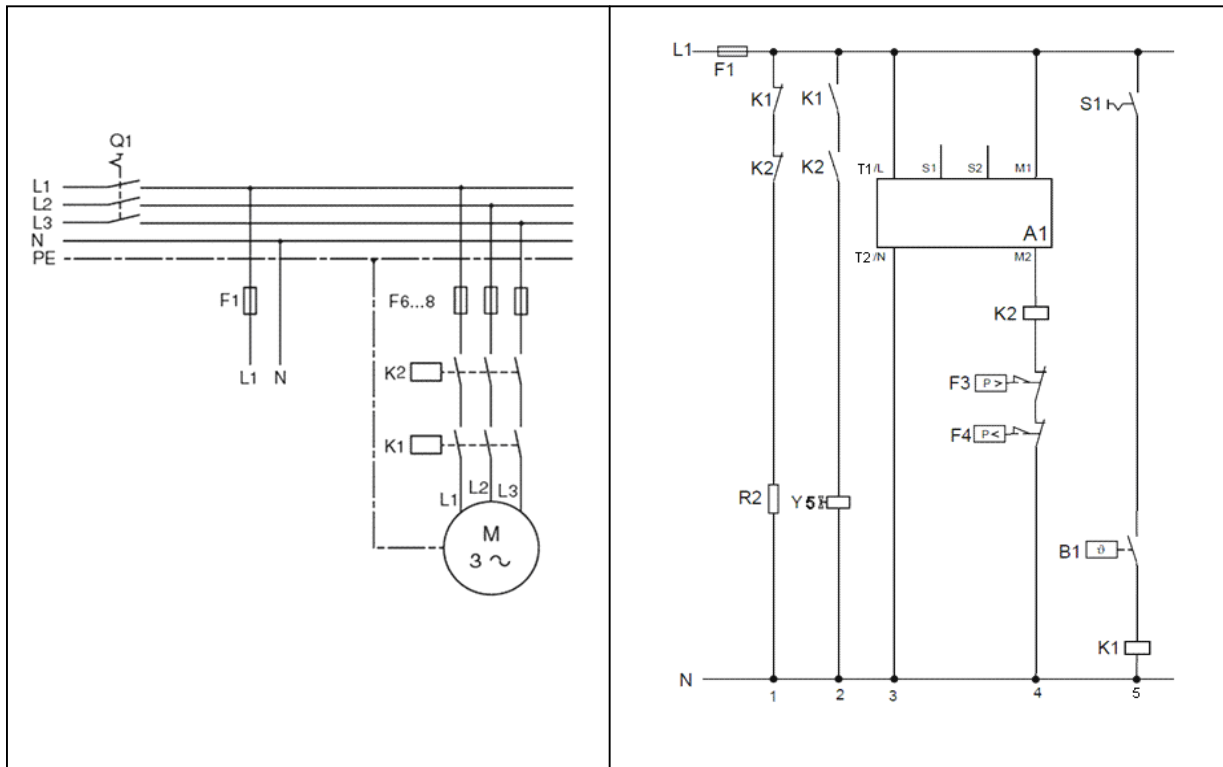

Motor terminal connections

Three-phase compressors are connected to the T1, T2 and T3 connections

Legend

A1	Motor protection module INT69SC2	K1, K2	Contactors
B1	Room thermostat	Q1	Main switch
F1, F6, F8	Fuses	R2	Crankspace heater
F3	HP switch	S1	Auxiliary switch
F4	LP switch		

Figure 11

4.2.1 Terminal box

The terminal box is IP21 for all models without electronic motor protection (eg, TF*/PF*) and IP54 for all models with electronic motor protection (eg, TW*).

4.2.2 Motor winding

The ZR/ZP Scroll compressors are offered either with a single-phase or a three-phase induction motor, depending on the size. All three-phase motors are connected in star; single-phase motors need a run capacitor.

The motor insulation material is class "B" (TF*) or "H" (TW*) for compressor models covered in this guideline.

4.2.3 Protection devices

Independently from the internal motor protection, fuses must be installed before the compressor. Selection of fuses has to be carried out according to VDE 0635, DIN 57635, IEC 269-1 or EN 60-269-1.

4.2.4 Crankcase heaters



IMPORTANT

Oil dilution! Bearing malfunction! Turn the crankcase heater on 12 hours before starting the compressor.

A crankcase heater is required when the system charge exceeds the compressor charge limits listed in **Table 3**.

Model	Refrigerant charge limit
ZR18K*	2.7 kg
ZR22K* to ZR81K* / ZP24K* to ZP83K*	4.5 kg
ZR94K* to ZR190K* / ZP90K* to ZP182K*	7.0 kg
ZR250K* / ZP235K*	11.3 kg
ZR310K* to ZR380K* / ZP295K* to ZP385K*	13.6 kg
ZP485K*	16.0 kg

Table 3

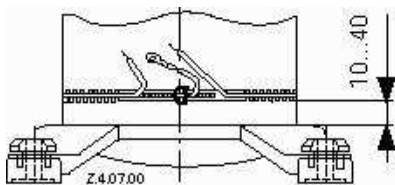

For compressors ZR18K* to ZR81K* and ZP24K* to ZP83K*, the crankcase heater must be mounted 10 to 40 mm above compressor legs (see **Figure 12**).

Figure 12: Crankcase heater location, models ZR18K* to ZR81K* & ZP24K* to ZP83K*

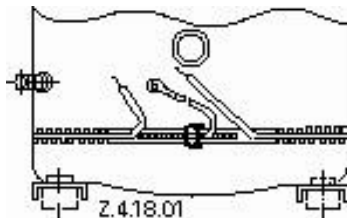

For all other compressor models, the crankcase heater must be mounted below the oil removal valve located on the bottom shell (see **Figure 13**).

Figure 13: Crankcase heater location, models ZR94K* to ZR380K* & ZP90K* to ZP485K*

4.3 Pressure safety controls

4.3.1 High-pressure control

A high-pressure control with a maximum cut-out setting of 28.8 bar(g) (ZR models) or 43 bar(g) (ZP models) respectively is recommended.

The high-pressure control should have a manual reset feature for the highest level of system protection.

4.3.2 Low-pressure control



IMPORTANT

Loss of system charge! Bearing malfunction! A low-pressure control is highly recommended for loss of charge protection. Do not bridge or by-pass the low-pressure cut out.

Even though these compressors have an internal discharge temperature protection, loss of system charge etc. will result in overheating and recycling of the motor protector. Prolonged operation in this manner could result in oil pump out and eventual bearing failure.

Normally, the low-pressure cut-out setting should be inside the approved operating envelope of the compressor taking into account the refrigerant used.

For air-conditioning applications, a cut-out setting not lower than 2 bar(g) for ZR R407C and 4.4 bar(g) for ZP R410A is recommended.

For heat pump applications, a cut-out setting not lower than 0.5 bar(g) for ZR R407C and 2 bar(g) for ZP R410A is recommended. Operation near a saturated suction temperature of -28°C is outside the approved operating envelope of the compressor. However, heat pumps in some geographical areas have to operate in this range because of the low ambient temperatures. This is acceptable as long as the discharge temperature is below 130°C.

These conditions can also be due to temporary suction blockage during reversing valve operation or lack of liquid pressure available to the metering device upon start up in heating mode.

An alternative is to keep the low-pressure control in the suction line and provide a 60-second maximum low-pressure time delay that ignores a signal from the low-pressure control and allows the compressor to continue operating.

The low-pressure cut-out, if installed in the suction line to the compressor, can provide additional protection against a TXV failed in the closed position, outdoor fan failure in heating, a closed liquid line or suction line service valve, or a blocked liquid line screen, filter, orifice, or TXV. All of these conditions may starve the compressor for refrigerant and may result in compressor failure.

The low-pressure cut-out should have a manual reset feature for the highest level of system protection.

4.3.3 Internal pressure relief valve

There is an internal pressure relief valve on all ZR18K* to ZR81K* and ZP24K* to ZP83K* compressors, which opens at a differential pressure of 28 bar \pm 3 bar for ZR compressors and 40 bar \pm 3 bar for ZP compressors between high- and low-pressure sides. A high-pressure cut-out may be required according to national regulations and is strongly recommended due to the capabilities of pumping to high pressures once the discharge is obstructed. The internal pressure relief valve is a safety device, not an HP switch. It is not designed for repeated operation and there is no guarantee that it will reset correctly if it does have repeated operation. The Summit Copeland Scroll™ compressors (7-15 HP) do not have internal pressure relief valves.

4.4 Discharge temperature protection

The ZR18K* to ZR81K* and ZP24K* to ZP83K* compressors have an internal thermo-disc discharge gas temperature protection. This thermo-disc opens a gas passage from the discharge port to the suction side near the motor protector when the discharged gas reaches a critical temperature. The hot gas then causes the motor protector to trip shutting down the compressor.

ZR94K* to ZR190K* and ZP90K* to ZP182K* Scroll compressors built in October 2004 and later (04J) have the addition of the Advanced Scroll Temperature Protection (ASTP). Advanced Scroll Temperature Protection is also a temperature sensitive thermo-disc that acts to protect the compressor from discharge gas overheating. Once the discharge gas reaches a critical temperature, the ASTP feature will cause the scrolls to separate and stop pumping although the motor continues to run. After running for some time without pumping gas, the motor protector will open.

To identify compressors with Advanced Scroll Temperature Protection, a label has been added above the terminal box.



Figure 14: Advanced Scroll Temperature Protection (ASTP)

NOTE: Depending upon the heat build-up in the compressor, it may take more than one hour for the ASTP and motor protector to reset!

For compressors ZR250K* to ZR380K* and ZP235K* to ZP485K*, a thermistor is located in the discharge port of the fixed scroll. Excessive discharge temperature will cause the electronic protector module to trip. The discharge gas thermistor is wired in series with the motor thermistor chain.

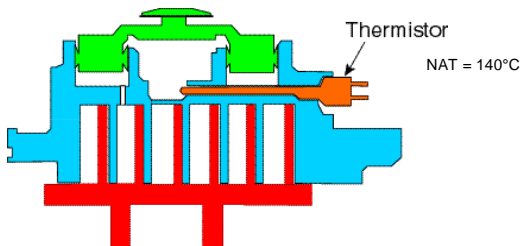
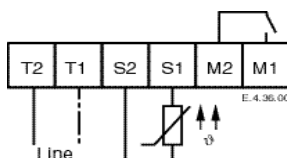

Figure 15: Internal discharge temperature sensor position

4.5 Motor protection

For the ZR18K* to ZR190K* and ZP24K* to ZP182K* range of compressors, conventional inherent internal line break motor protection is provided.

The electronic motor protection system used in all ZR250K* to ZR380K* and ZP235K* to ZP485K* models is identified by a "W" as the centre letter in the motor code. This system utilizes the temperature-dependent resistance of the thermistors (also called PTC-resistance) to read the winding temperature. A chain of four thermistors connected in series is embedded in the motor windings so that the temperature of the thermistors can follow the winding temperature with little inertia. An electronic module is required to process the resistance values and trip a control depending on the thermistor resistance.



- L1/T1 neutral connection
- L2/T2 line voltage connection
- S1, S2 thermistor chain connection
- M1, M2 control circuit connection

Figure 16: Wiring of the motor protection module

Module

For protection in case of blocked rotor one thermistor for each phase is embedded in the winding heads on the upper (suction gas) side of the compressor motor. A fourth thermistor is located in a winding head at the lower end of the motor. A fifth sensor is located in the discharge port of the fixed scroll to control discharge-gas superheat. The entire chain is internally led to the fusite from where it is connected to the module connections S1 and S2.

When any resistance of the thermistor chain reaches the tripping value, the module interrupts the control line and causes the compressor to switch off. After the thermistor has cooled sufficiently, its resistance drops to the reset value but the module itself resets after a time delay of 30 minutes and restarts the compressor.

Supply voltage: Dual voltage	115-230V AC 50 Hz, -15%...+10%, 3VA
Supply voltage: Dual voltage	120-240V AC 60 Hz, -15%...+10%, 3VA
Supply voltage	24V AC 50/60 Hz, -15%...+10%, 3VA
Supply voltage	24V DC \pm 20%, 2W
Ambient temperature range	-30...+70°C
R ₂₅ , total	< 1,8k Ω
Trip resistance	4,50k Ω \pm 20%
Reset time delay type 1 / type 2	30 min \pm 5 min / 60 min \pm 5 min
Reset of running time	Power interruption / mains failure for approx. 5 sec
Short circuit monitoring system	Typically < 30 Ω
Protection class according to EN 60529	IP00
Weight	Approximately 200 g
Mounting	Screw in or snap in
Housing material	PA66 GF25 FR

Table 4: Protection module specifications INT69SC2

4.6 Protector functional check and failure detection

Prior to start-up of the compressor a functional check shall be carried out:

- Switch off power!
- Disconnect one terminal either S1 or S2 of the electronic module. If the compressor is now switched on, the motor should not start.
- Switch off power.
- Reconnect the disconnected thermistor line. If the compressor is now switched on, the motor must start.

Protector fault diagnosis

If the motor does not start-up during the functional check, this indicates a disturbance in operation:

- Switch off power.
- Check the connection of the thermistor leads in the terminal box and at the protection module for possible loose connections and check the connection cable for possible breakage.
- The resistance of the thermistor chain shall be measured in a cold condition, ie, after the motor has sufficiently cooled down.

Caution: Use maximum measuring voltage of 3 V!

In doing so, the thermistor leads at terminals S1 and S2 of the module shall be disconnected and measured between the leads. Resistance must be between 150 and 1250 Ohms.

If the thermistor chain has a higher resistance (2750 Ohms or greater), the motor temperature is still too high and it has to be allowed to cool.

If the resistance is 0 Ohms, the compressor has to be exchanged due to shorted sensor circuit. ∞ Ohms indicates an open sensor circuit and the compressor has to be replaced.

If no defect is located in the thermistor chain or there is no loose contact or conductor breakage, the module shall be checked. Then the control connections at M1 and M2 have to be removed (Caution! Switch off voltage supply first!) and the switching conditions must be checked by an ohmmeter or signal buzzer:

- Bridge the already disconnected thermistor contactors S1 and S2 and switch on the voltage supply; the relay must switch; connection established between contactors M1 and M2
- Remove the jumper between S1 and S2, the relay must switch off; no connection between contactors M1 and M2

- Bridge the contactors S1 and S2 again, the relay remains switched off; no connection between contactors M1 and M2
- Switch off the voltage supply for approximately 4 seconds and switch it on again, the relay must switch on now; connection between contactors M1 and M2

If one of the above conditions is not met, the module is defective and has to be exchanged.

NOTE: The power should be switched off between the tests in order to avoid short circuits and accidental touching of contacts. The function of the module should be tested each time the fuse in the control circuit breaks the power supply. This ensures the contacts did not stick.

4.7 High-potential testing



WARNING

Conductor cables! Electrical shock! Shut off power supply before high-potential testing.



CAUTION

Internal arcing! Motor destruction! Do not carry out high-voltage or insulation tests if the compressor housing is under vacuum.

Emerson Climate Technologies subjects all Scroll compressors to a high-voltage test after final assembly. Each motor phase winding is tested, according to EN 0530 or VDE 0530 part 1, at a differential voltage of 1000V plus twice the nominal voltage. Since high-voltage tests lead to premature ageing of the winding insulation additional tests of that nature are not recommended.

If it has to be done for any reason, a lower voltage must be used. Disconnect all electronic devices, eg, motor protection module, fan speed control, etc prior to testing.

5 Starting up & operation



WARNING

Diesel effect! Compressor destruction! The mixture of air and oil at high temperature can lead to an explosion. Avoid operating with air.

5.1 Strength pressure test

The compressor has been strength-tested in the factory. It is not necessary for the customer to strength- or leak-test the compressor again although the compressor will normally be exposed to the testing made as part of system testing.

5.2 Tightness/pressure test



WARNING

High pressure! Personal injuries! Consider personal safety requirements and refer to test pressures prior to test.



WARNING

System explosion! Personal injuries! DO NOT USE other industrial gases.



CAUTION

System contamination! Bearing malfunction! Use only dry nitrogen or dried air for pressure testing.

If using dry air do not include the compressor in the pressure test – isolate it first. Never add refrigerant to the test gas (as leak indicator).

5.3 Preliminary checks – Pre-starting

Discuss details of the installation with the installer. If possible, obtain drawings, wiring diagrams, etc. It is ideal to use a check-list but always check the following:

- Visual check of the electrics, wiring, fuses etc.
- Visual check of the plant for leaks, loose fittings such as TXV bulbs etc.
- Compressor oil level
- Calibration of HP & LP switches and any pressure actuated valves
- Check setting and operation of all safety features and protection devices
- All valves in the correct running position
- Pressure and compound gauges fitted
- Correctly charged with refrigerant
- Compressor electrical isolator location & position

5.4 Charging procedure



CAUTION

Low suction pressure operation! Compressor Damage! Do not operate with a restricted suction. Do not operate with the low-pressure cut-out bridged. Do not operate compressor without enough system charge to maintain at least 0.5 bar suction pressure. Allowing pressure to drop below 0.5 bar for more than a few seconds may overheat scrolls and cause early drive bearing damage.

The system should be liquid-charged through the liquid-receiver shut-off valve or through a valve in the liquid line. The use of a filter drier in the charging line is highly recommended. Because R410A and R407C are blends and scrolls have discharge check valves, systems should be liquid-charged on both the high and low sides simultaneously to ensure a positive refrigerant pressure is present in the compressor before it runs. The majority of the charge should be placed in the high side of the system to prevent bearing washout during first-time start on the assembly line.

5.5 Initial start-up



CAUTION

Oil dilution! Bearing malfunction! It is important to ensure that new compressors are not subjected to liquid abuse. Turn the crankcase heater on 12 hours before starting the compressor.



CAUTION

High discharge pressure operation! Compressor damage! Do not use compressor to test opening set point of high-pressure cut-out. Bearings are susceptible to damage before they have had several hours of normal running in.

Liquid and high pressure loads could be detrimental to new bearings. It is therefore important to ensure that new compressors are not subjected to liquid abuse and high-pressure run tests. It is not good practice to use the compressor to test the high-pressure switch function on the production line. Switch function can be tested with nitrogen prior to installation and wiring can be checked by disconnecting the high-pressure switch during the run test.

5.6 Rotation direction

Scroll compressors, like several other types of compressors, will only compress in one rotational direction. Direction of rotation is not an issue with single-phase compressors since they will always start and run in the proper direction. Three-phase compressors will rotate in either direction depending upon phasing of the power. Since there is a 50-50 chance of connecting power in such a way as to cause rotation in the reverse direction, **it is important to include notices and instructions in appropriate locations on the equipment to ensure proper rotation direction when the system is installed and operated.**

Observing that suction pressure drops and discharge pressure rises when the compressor is energized allows verification of proper rotation direction. There is no negative impact on durability caused by operating three-phase Copeland Scroll™ compressors in the reversed direction for a short period of time (under one hour) but oil may be lost. Oil loss can be prevented during reverse rotation if the tubing is routed at least 15 cm above the compressor. After several minutes of operation in reverse, the compressor's protection system will trip due to high motor temperature. The operator will notice a lack of cooling. However, if allowed to repeatedly restart and run in reverse without correcting the situation, the compressor will be permanently damaged.

All three-phase scroll compressors are identically wired internally. Therefore, once the correct phasing is determined for a specific system or installation, connecting properly phased power leads to the identified compressor terminals will ensure proper rotation direction.

5.7 Starting sound

During the very brief start-up, a clicking sound is audible, resulting from initial contacting of the spirals and is normal. Due to the design of the Copeland Scroll, the internal compression components always start unloaded even if system pressures are not balanced. In addition, since internal compressor pressures are always balanced at start-up, low-voltage starting characteristics are excellent for Copeland Scroll™ compressors.

5.8 Deep vacuum operation



CAUTION

Vacuum operation! Compressor damage! Scroll compressors should never be used to evacuate a refrigeration or air-conditioning system.

The scroll compressor can be used to pump down refrigerant in a unit as long as the pressures remain within the operating envelope. Low suction pressures will result in overheating of the scrolls and permanent damage to the compressor drive bearing. ZP and ZR scrolls incorporate internal low vacuum protection; the floating seal unloads when the pressure ratio exceeds approximately 10:1.

5.9 Shell temperature

The top shell and discharge line can briefly but repeatedly reach temperatures above 177°C if the compressor cycles on its internal protection devices. This only happens under rare circumstances and can be caused by the failure of system components such as the condenser or evaporator fan or loss of charge and depends upon the type of expansion control. Care must be taken to ensure that wiring or other materials that could be damaged by these temperatures do not come in contact with the shell.

5.10 Pump down cycle

A pump down cycle for control of refrigerant migration may be used in conjunction with a crankcase heater when the compressor is located so that cold air blowing over the compressor makes the crankcase heater ineffective.

If a pump down cycle is used, a separate external check valve must be added. The scroll discharge check valve is designed to stop extended reverse rotation and prevent high-pressure gas from leaking rapidly into the low side after shut off. The check valve will in some cases leak more than reciprocating compressor discharge reeds, normally used with pump down, causing the scroll compressor to recycle more frequently. Repeated short-cycling of this nature can result in a low oil situation and consequent damage to the compressor. The low-pressure control differential has to be reviewed since a relatively large volume of gas will re-expand from the high side of the compressor into the low side after shutdown.

Pressure control setting: Never set the low-pressure control to shut off outside of the operating envelope. To prevent the compressor from running into problems during such faults as loss of charge or partial blockage, the control should not be set lower than 12 to 15 K equivalent suction pressure below the lowest design operating point.

5.11 Minimum run time

Emerson Climate Technologies recommends a maximum of 10 starts per hour. There is no minimum off time because scroll compressors start unloaded, even if the system has unbalanced pressures. The most critical consideration is the minimum run time required to return oil to the compressor after start-up. To establish the minimum run time obtain a sample compressor equipped with a sight tube (available from Emerson Climate Technologies) and install it in a system with the longest connecting lines that are approved for the system. The minimum on time becomes the time required for oil lost during compressor start-up to return to the compressor sump and restore a minimal oil level that will ensure oil pick-up through the crankshaft. Cycling the compressor for a shorter period than this, for instance to maintain very tight temperature control, will result in progressive loss of oil and damage to the compressor.

5.12 Shut-off sound

The Scroll compressors incorporate a device which limits reverse rotation. The momentary reversal of direction of the scrolls has no effect on compressor durability and is entirely normal.

6 Maintenance & repair

6.1 Exchanging the refrigerant

Qualified refrigerants and oils are given in section 2.4.1.

It is not necessary to replace the refrigerant with new unless contamination due to an error such as topping up the system with an incorrect refrigerant is suspected. To verify correct refrigerant composition, a sample can be taken for chemical analysis. A check can be made during shut down by comparing the refrigerant temperature and pressure using precision measurements at a location in the system where liquid and vapour phases are present and when the temperatures have stabilised.

In the event that the refrigerant needs replacing, the charge should be recovered using a suitable recovery unit.

In the event that R22 in a system with mineral oil is to be replaced with R407C, the oil must also be changed. Please refer to Technical Information C7.26.1 "Refrigerant Changeover from HCFC to HFC Refrigerants".

6.2 Rotalock valves

Rotalock valves should be periodically re-torqued to ensure that leak tightness is maintained.

6.3 Replacing a compressor



CAUTION

Inadequate lubrication! Bearing destruction! Exchange the accumulator after replacing a compressor with a burned out motor. The accumulator oil return orifice or screen may be plugged with debris or may become plugged. This will result in starvation of oil to the new compressor and a second failure.

6.3.1 Compressor replacement

In the case of a motor burnout, the majority of contaminated oil will be removed with the compressor. The rest of the oil is cleaned through the use of suction and liquid line filter driers. A 100% activated alumina suction line filter drier is recommended but must be removed after 72 hours. **It is highly recommended that the suction accumulator be replaced if the system contains one.** This is because the accumulator oil-return orifice or screen may be plugged with debris or may become plugged shortly after a compressor failure. This will result in starvation of oil to the replacement compressor and a second failure. When a single compressor or tandem is exchanged in the field, it is possible that a major portion of the oil may still be in the system. While this may not affect the reliability of the replacement compressor, the extra oil will add to rotor drag and increase power usage.

6.3.2 Start-up of a new or replacement compressor

Rapid charging only on the suction side of a scroll-equipped system or condensing unit can occasionally result in a temporary no start condition for the compressor. The reason for this is that, if the flanks of the compressor happen to be in a sealed position, rapid pressurisation of the low side without opposing high-side pressure can cause the scrolls to seal axially. As a result, until the pressures eventually equalise, the scrolls can be held tightly together preventing rotation. The best way to avoid this situation is to charge on both the high and low sides simultaneously at a rate which does not result in axial loading of the scrolls.

A minimum suction pressure of 1.75 bar must be maintained during charging. Allowing pressure to drop below 0.5 bar for more than a few seconds may overheat scrolls and cause early drive bearing damage. Never install a system in the field and leave it unattended when it has no charge, a holding charge, or with the service valves closed without securely electrically locking out the system. This will prevent unauthorised personnel from accidentally operating the system and potentially ruining the compressor by operating with no refrigerant flow. **Do not start the compressor while the system is in a deep vacuum.** Internal arcing may occur when a scroll compressor is started in a vacuum causing burnout of the internal lead connections.

6.4 Lubrication and oil removal



CAUTION

Chemical reaction! Compressor destruction! Do not mix up ester oils with mineral oil and/or alkyl benzene when used with chlorine-free (HFC) refrigerants.

The compressor is supplied with an initial oil charge. The standard oil charge for use with refrigerants R407C / R410A / R134a is a polyolester (POE) lubricant Emkarate RL 32 3MAF. In the field the oil level could be topped up with Mobil EAL Arctic 22 CC if 3MAF is not available. The standard mineral oil for R22 is Suniso 3GS or Copeland White Oil according to compressor model. See nameplate for original oil charge shown in litres. A field recharge is from 0.05 to 0.1 litre less.

One disadvantage of POE is that it is far more hygroscopic than mineral oil (see **Figure 17**). Only brief exposure to ambient air is needed for POE to absorb sufficient moisture to make it unacceptable for use in a refrigeration system. Since POE holds moisture more readily than mineral oil it is more difficult to remove it through the use of vacuum. Compressors supplied by Emerson Climate Technologies contain oil with low moisture content, and it may rise during the system assembling process. Therefore it is recommended that a properly sized filter-drier is installed in all POE systems. This will maintain the moisture level in the oil to less than 50 ppm. If oil is charged into a system, it is recommended to use POE with a moisture content no higher than 50 ppm.

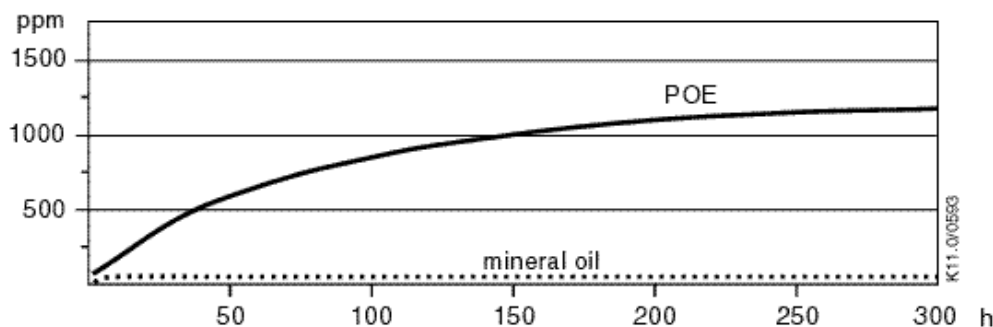

Figure 17: Absorption of moisture in ester oil in comparison to mineral oil in ppm by weight at 25°C and 50% relative humidity (h=hours)

If the moisture content of the oil in a refrigeration system reaches unacceptably high levels, corrosion and copper plating may occur. The system should be evacuated down to 0.3 mbar or lower. If there is uncertainty as to the moisture content in the system, an oil sample should be taken and tested for moisture. Sight glass/moisture indicators currently available can be used with the HFC refrigerants and lubricants; however, the moisture indicator will just show the moisture content of the refrigerant. The actual moisture level of POE would be higher than the sight glass indicates. This is due to the high hygroscopicity of the POE oil. To determine the actual moisture content of the lubricant, samples have to be taken from the system and analysed.

6.5 Unbrazing system components



WARNING

Explosive flame! Burning! Oil-refrigerant mixtures are highly flammable. Remove all refrigerant before opening the system. Avoid working with an unshielded flame in a refrigerant charged system.

Before opening up a system it is important to remove all refrigerant from both the high and low sides of the system. If the refrigerant charge is removed from a scroll-equipped unit from the high side only, it is possible for the scrolls to seal, preventing pressure equalization through the compressor. This may leave the low side shell and suction line tubing pressurized. If a brazing torch is then applied to the low side while the low side shell and suction line contain pressure, the pressurized refrigerant and oil mixture could ignite when it escapes and contacts the brazing flame. To prevent this occurrence, it is important to check both the high and low sides with manifold gauges before unbrazing. Instructions should be provided in appropriate product literature and assembly (line repair) areas. If compressor removal is required, the compressor should be cut out of system rather than unbrazed.

7 Dismantling & disposal



Removing oil and refrigerant:
Do not disperse in the environment.
Use the correct equipment and method of removal.
Dispose of oil and refrigerant properly.
Dispose of compressor properly.

Benelux
Deltakade 7
5928 PX Venlo
Tel. +31 77 324 02 34
Fax +31 77 324 02 35
benelux.sales@emerson.com

Germany, Austria & Switzerland
Senefelder Str. 3
63477 Maintal
Tel. +49 6109 605 90
Fax +49 6109 60 59 40
ECTGermany.sales@emerson.com

France, Greece & Maghreb
8, Allée du Moulin Berger
69130 Ecully Cédex
Tel. +33 4 78 66 85 70
Fax +33 4 78 66 85 71
mediterranean.sales@emerson.com

Italy
Via Ramazzotti, 26
21047 Saronno (VA)
Tel. +39 02 96 17 81
Fax +39 02 96 17 88 88
italy.sales@emerson.com

Spain & Portugal
Diputación, 238 AT-8
08007 Barcelona
Tel. +34 93 412 37 52
Fax +34 93 412 42 15
iberica.sales@emerson.com

UK & Ireland
Unit 17, Theale Lakes Business Park
Reading, Berks RG7 4GB
Tel: +44 1189 83 80 00
Fax: +44 1189 83 80 01
uk.sales@emerson.com

Sweden, Denmark, Norway & Finland
Pascalstr. 65
52076 Aachen
Tel. +49 2408 92 91 27
Fax +49 2408 92 95 28
nordic.sales@emerson.com

Eastern Europe, Turkey & Iran
Pascalstr. 65
52076 Aachen
Tel. +49 2408 929 0
Fax +49 2408 929 525
easterneurope.sales@emerson.com

Poland
ul. Konstruktorska 11A
02-673 Warszawa
Tel. +48 22 458 92 05
Fax +48 22 458 92 55
poland.sales@emerson.com

Russia & CIS
Letnikovskaya Str. 10, Bldg. 2, 5th floor
115114 Moscow
Tel. +7 495 981 98 11
Fax +7 495 981 98 16
ECT.Holod@emerson.com

Balkan
Selska cesta 93
10 000 Zagreb
Tel. +385 1 560 38 75
Fax +385 1 560 38 79
balkan.sales@emerson.com

Asia & Pacific
10/F, Pioneer Building, 213 Wai Yip Street,
Kwun Tong, Kowloon - Hong Kong
Tel. +852 28 66 31 08
Fax +852 25 20 62 27
asiapacific.sales@emerson.com

Latin America
7975 North West 154Th Street - Suite 300
Miami Lakes, FL, 33016 - USA
Tel. +1 305 818 88 80
Fax +1 305 818 88 88
latinamerica.sales@emerson.com

Middle East & Africa
PO Box 26382
Jebel Ali Free Zone - South, Dubai - UAE
Tel. +971 4 811 81 00
Fax +971 4 886 54 65
mea.sales@emerson.com

Copeland
brand products

Emerson Climate Technologies GmbH - European Headquarters - Pascalstrasse 65 - 52076 Aachen, Germany
Tel. +49 2408 92 90 - Fax: +49 2408 92 95 70 - www.emersonclimate.eu

The Emerson Climate Technologies logo is a trademark and service mark of Emerson Electric Co. Emerson Climate Technologies Inc. is a subsidiary of Emerson Electric Co. Copeland is a registered trademark and Copeland Scroll is a trademark of Emerson Climate Technologies Inc.. All other trademarks are property of their respective owners. Information contained in this brochure is subject to change without notification.

© 2008 Emerson Climate Technologies, Inc.

EMERSON
Climate Technologies

EMERSON. CONSIDER IT SOLVED.